

BROKIS® CATALOGUE

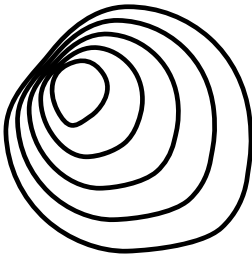

A TRADITIONALLY CRAFTED
CONTEMPORARY VISION OF LIGHT

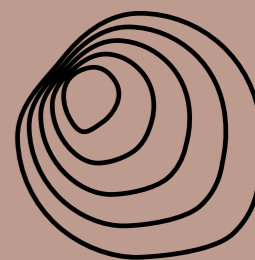

BROKIS®

BROKIS



BROKIS – a synthesis of exquisite design, superior quality, and the skill of master artisans continuing the centuries-old Bohemian glassmaking tradition. BROKIS lighting collections have achieved international acclaim by combining handblown glass with other refined materials, such as handcrafted wood and metal, in bold compositions that push

the boundaries not only of contemporary lighting design but of the technologies applied in production. The family-run premium brand works with select designers from around the world and operates its own historical glassworks southeast of Prague. Each BROKIS light is a genuine original, a functional work of art as captivating by day as it is by night.



BROKIS is the brainchild of successful Czech entrepreneur Jan Rabell. In 2006, he founded the brand as a platform to enliven and elevate Bohemian glassmaking to new heights and preserve generations of knowledge and craftsmanship. Nearly ten years prior, in 1997, he acquired the ailing Janštejn Glassworks, founded at the start of the 19th century approximately 140 kilometres southeast of Prague. Demand for traditional products had declined significantly, many of the glassmakers were growing old and leaving, and time-honoured technologies and techniques were at risk of being lost. Mr. Rabell's vision was to restore the factory to its former prestige and ensure that the ages-old Bohemian glassmaking tradition endured into the 21st century.

With BROKIS, Jan Rabell created a lighting brand offering entirely different products than those previously produced at Janštejn Glassworks. Several new Italian-style furnaces were built, and production techniques were refined. Some, such as grinding and glass painting, were discontinued, and others were revived, like glassblowing using optic moulds and traditional hotshop techniques. Original and nearly forgotten formulas for manufacturing coloured glass were reinstated and are now characteristic of the BROKIS brand.

BROKIS has firmly established itself as a leading innovator in glass lighting. For example, the complex technology applied in manufacturing the Night Birds collection, which consists of imposing yet elegant curved glass silhouettes of birds in various phases of flight, required two years of experimentation to perfect. BROKIS is constantly developing new technologies for its lights in order to offer consistent industry-leading quality and innovation throughout its global product portfolio, such as with a special original connector or the all-new sustainable material called BROKISGLASS. BROKIS also maintains a strong online presence through a series of innovative projects, such as BROKIS VIRTUAL PROJECTS and the unique MyBrokis application. In January of 2022, BROKIS launched a new website unified within JGG. Today, BROKIS and Janštejn Glassworks employ more than 100 people and enjoy a unique symbiosis that has allowed BROKIS to establish sales operations in 100 countries and regularly showcase its renowned lighting collections at the world's top design shows.

PRESERVING THE BOHEMIAN GLASSBLOWING TRADITION



JANŠTEJN GLASSWORKS

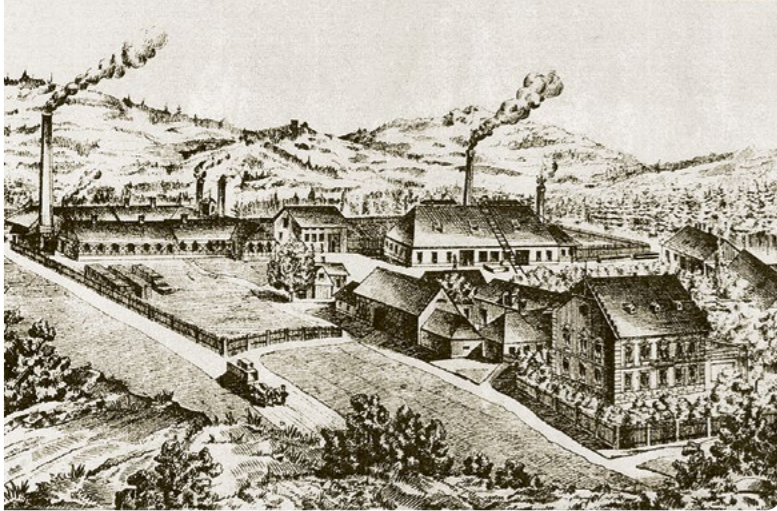

For more than 200 years, Janštejn Glassworks, situated in Bohemia's picturesque Vysočina Region, has upheld a glassblowing tradition that dates to the end of the 17th century. Founded in 1809 near the village of Horní Dubenky, the factory and generations of tenacious craftspeople employed by it

have enjoyed periods of prosperity yet have also endured much hardship, with three devastating fires, two world wars, and nationalization among their greatest challenges. Today, Janštejn Glassworks is the largest producer of specialty lighting glass in the Czech Republic.



Entrepreneur Jan Rabell is one of the most dynamic figures in the Czech Republic's glassmaking industry. Born in Prague in 1965 to a Puerto Rican father and Czech mother, he grew up in his father's homeland, later returning to Prague to pursue a master's degree in economics. He went on to hold various managing director posts in the field of finance and banking. In 1997, he purchased the ailing Janštejn Glassworks and set about restoring its prestige

and competitiveness primarily by introducing unconventional glassblowing techniques and production technologies. In 2006, he founded the family-run premium glass lighting brand BROKIS, quickly developing it into one of the most important players in the market and exporting its products around the world. Mr Rabell's charisma, energy, and innovative vision continue to propel BROKIS and Janštejn Glassworks steadily forward.



**“NOTHING’S IMPOSSIBLE;
NEVER SAY IT CAN’T BE DONE.”**

PEOPLE: JAN RABELL

BROKIS art director Lucie Koldova is an acclaimed Czech product and furniture designer. Her collaboration with the lighting brand began in 2010 with the timeless Muffins and Balloons collections, which she designed while living and working in Paris. The voluminous glass lights embody her charismatic, elegant style and quickly established BROKIS as an innovative producer of handblown glass lighting. She is the creative force behind the brand and is instrumental in shaping its product portfolio and image.

Her creations, objects of desire, include glass sculptures, glass lighting, poetic gallery pieces, and limited-series works. Breathtaking colours, unusual proportions, and vibrant formal contrasts move her work seemingly beyond the realm of the possible, a trademark at once apparent in lighting collections such as Balloons, Macaron, Puro, and Ivy. In addition to developing ever-more novel and exciting motifs, Lucie Koldova has introduced important technological and formal solutions that have enabled BROKIS to push the limits of handblown glass production.

PEOPLE: LUCIE KOLDOVA



“I SEE A LIGHT AS A SCULPTURE – AN OBJECT RADIATING ENERGY. I SHAPE THE ENERGY OF LIGHT THROUGH THE RELATIONSHIP BETWEEN THE SOURCE AND THE GLASS.”

SUSTAINABILITY



In terms of ecology, BROKIS has come a long way since it was established in 2006. The BROKISGLASS project was established to reuse waste glass through recycling. Arising from the ecological manufacturing practices of Janštejn Glassworks and BROKIS, it resulted in the creation of an innovative material made of glass shards discarded in the manufacture of BROKIS glass lighting collections. The project currently produces ten tons of new flat glass each week. BROKISGLASS has brought about a significant

reduction in waste material. The transformation of these shards into a new decorative product represents an environmentally friendly and efficient upcycling of material, thanks to which the glassworks is able to employ a strategic circular economy and thus contribute to the cultivation of a healthy relationship between nature and humans. Already, there are procedures for new glass blends that can be added to other materials, such as concrete, in order to achieve 100% reuse of waste glass shards.



VIRTUAL PROJECTS



To show you just how remarkable our lighting collections really are, we've created two amazing virtual projects. Last year saw the launch of our acclaimed virtual villa, and in 2022 we introduced our new virtual boutique hotel.

The virtual villa offers architects, interior designers, and end customers a unique opportunity to view the majority of our collections under one roof, in a single villa featuring refined and timeless interiors. During the tour of the villa, which spans more than 900 virtual square metres across eight rooms and two outdoor terraces, you'll discover more than 15 perspectives, each providing a detailed view of the unique lighting compositions, including close-ups of individual lights and possible combinations and colour options together with a summary of the most important information for each collection. The new virtual boutique hotel features not only the most popular collections in the BROKIS portfolio

but also the latest ones. The grand scale of the virtual space makes it possible to combine conventional lights with our highly popular battery-powered lights. In the virtual boutique hotel, there are luxury suites, a restaurant, a bar, and an outdoor terrace with swimming pool. The premises of the hotel are expansive, so there is plenty of room to let your imagination run free.

Our lighting collections are showcased in 14 extraordinary scenes, each of which beckons visitors to dream big.

The intensity of the light of the individual collections is based on photometric measurements (LDT files) to ensure the virtual rendering is as realistic as possible. Walk around. Linger for a while at a spot that especially catches your imagination. Do a bit of day-dreaming. Light and art exist to evoke emotion in us. Indulge in the experience.



**BROKIS
DESIGN BY**

LUCIE KOLDOVA

DAN YEFFET

BORIS KLIMEK

CHIARAMONTE MARIN

FUMIE SHIBATA

LENKA DAMOVÁ

VRTIŠKA & ŽÁK

LCM MARIN DESIGN STUDIO

**INTERIOR
LIGHTS**

MUFFINS



The timeless Muffins collection represents an extraordinary lighting experience. Since its market debut, it has taken on an iconic status and become a symbol of the BROKIS brand. The sublimity of the design lies in the masterful combination of delicately contoured glass and solid wood. The lights, featuring a billowing glass shade set in a handcrafted wood base together with a naked

filament bulb, breathe new life into any space and elicit a festive ambience. The collection offers multiple shape and size variants as well as a broad palette of glass colours and woods. To celebrate ten years since the introduction of Muffins, a special anniversary edition was created in 2020 combining wood in high gloss with marble and different colours of glass.

DESIGN

LUCIE KOLDOVA, DAN YEFFET









BALLOONS



Balloons, a collection of timeless lights embodying rudimentary forms that evoke images of hot-air balloons, captivates with the beauty of large-format handblown glass and an elegant metal reflector hovering within. The design's charm lies in the use of two independent glass sections to achieve the impression of an integral whole. Lavish proportions and an elegant hand-pressed metal reflector are the collection's

defining traits. The size of the largest shade pushes the very boundaries of glassblowing technology and illustrates the exceptional skill and craftsmanship of Bohemian glassmakers. The Balloons collection is one of the pillars of the BROKIS portfolio. The lights come in three sizes. Balloons also make an outstanding sculptural statement during the day when they are switched off.

DESIGN

LUCIE KOLDOVA, DAN YEFFET





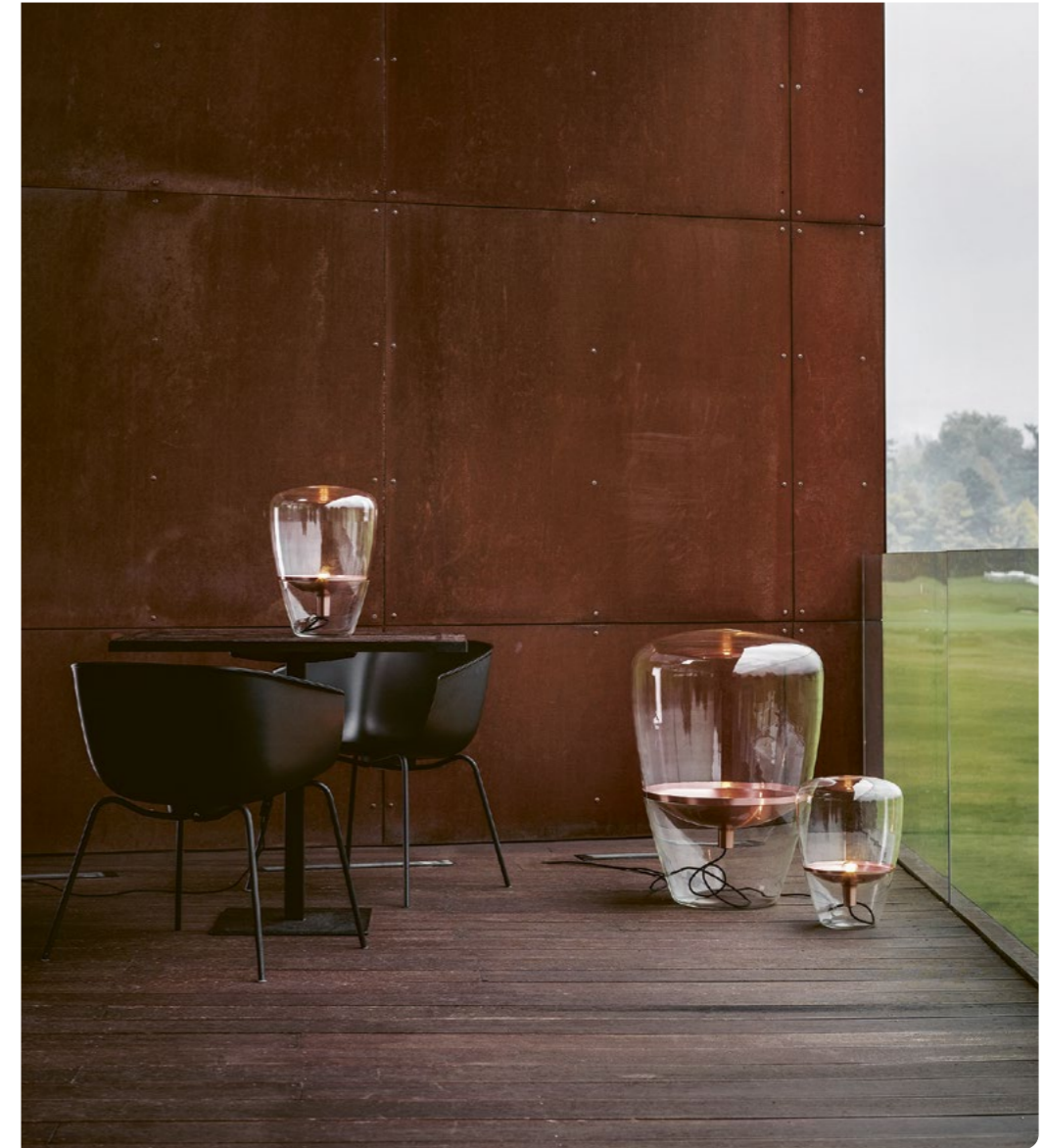



The Shadows collection is a take on the famed, timeless lights found in French ateliers, and its typology pays tribute to that legacy. The combination of hand-blown glass, handcrafted wood, and classic shaping has given rise to a light of ageless elegance. The collection comprises four different suspension lights, as striking alone as they are in sets, characterized by a handblown glass shade set upon on a handcrafted wooden fixture. The clean contours and finish are accentuated by the concealed light source. The Shadows collection is special not only for its wide spectrum of glass colour options, surface finishes,

DESIGN

and types of wood but also because the lights can be combined in sets according to customer requirements. They are intended for interiors and, thanks to multiple combination possibilities, are well suited to a broad range of installations. The contours of the Shadows XL collection stay true to the original Shadows collection but are nearly 50% bolder in their proportions. There is also an outdoor version for installation in exterior settings. All the Shadows collections have special integrated connectors developed by BROKIS to facilitate installation and cleaning.

LUCIE KOLDOVA, DAN YEFFET



SHADOWS









MEMORY

The Memory collection awakens the imagination and beckons back to a carefree childhood. The wall and ceiling versions in different sizes, the wide range of colour options, and a selection of finishes give this lighting experience a large degree of versatility. The illusion of inflated balloons is flawless right

DESIGN

down to the dangling string, which serves to switch the light on and off. This is beauty in its simplest and most persuasive form. The Memory collection consists of ceiling and wall versions in three sizes. There are also sets that allow multiple lights to be combined on a single ceiling canopy.

BORIS KLIMEK



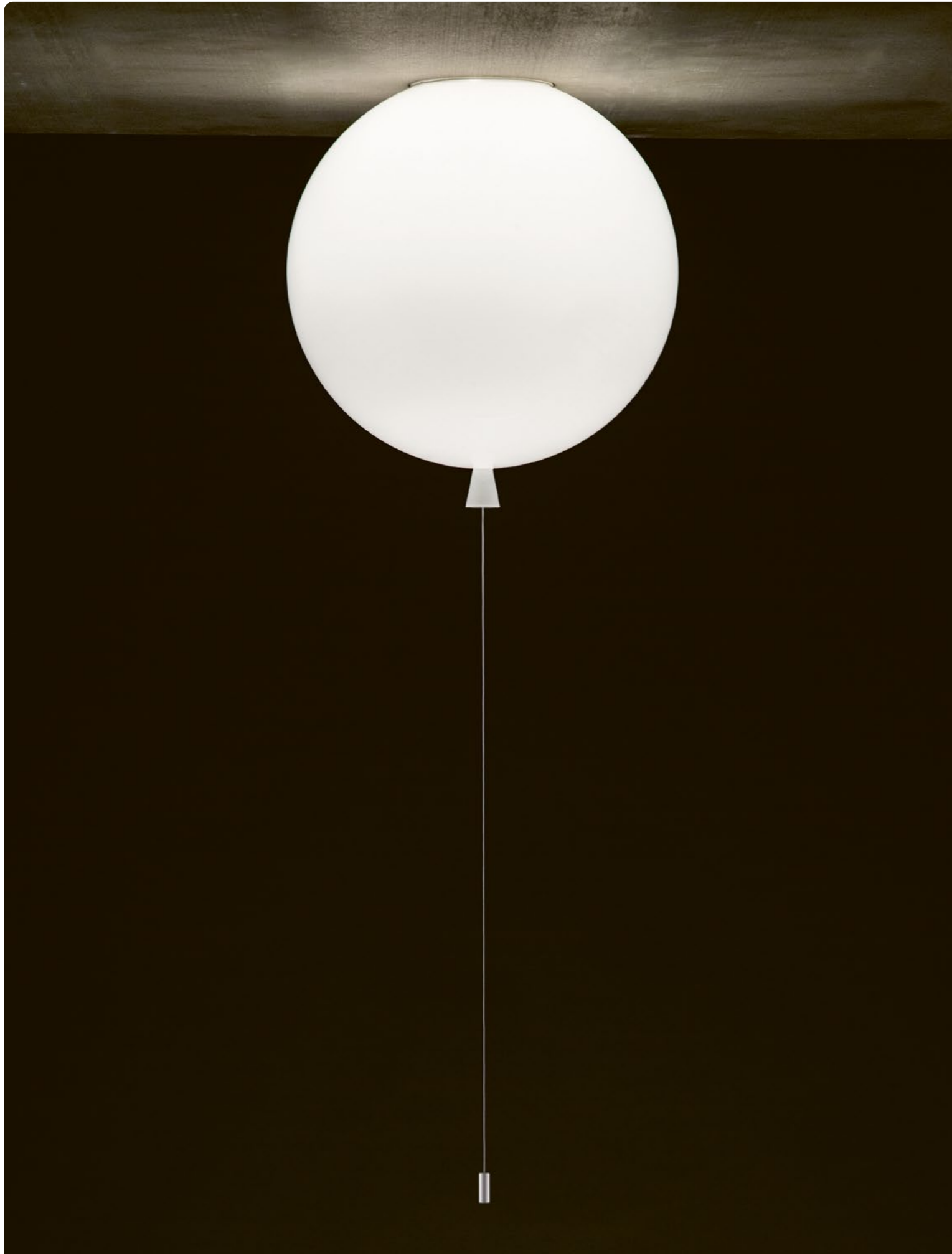





Capsula is a sophisticated and exhilarating light bearing resemblance to a plant cell or seed. The nucleus of the piece is a tubular triplex-glass LED light source, developed by BROKIS, that transects the inner shade and translucent external shell to form a notional axis. The layering and overlapping of these three distinct components give rise to dramatic 3D optical effects. The end caps fasten the components together and serve as anchor points for the creative

DESIGN

dual suspension straps, which also conceal the power cable and allow for variation in the final positioning of the light. The Capsula collection is offered in sets as well as individual lights that can be combined per customer requirements.

From spring 2018, Capsula is fitted with special integrated connectors developed by BROKIS to facilitate installation and cleaning.

LUCIE KOLDOVA



CAPSULA











The Mona collection is based on the concept of penetrating forms. The light source boldly traverses the ample volume of smooth handblown glass to reveal the thrilling tension inherent in the design. The collection's essence, however, lies in its unconventional construction and refined combination of

materials. It also boasts dimmable tubular LED light sources, developed by BROKIS, each with a different colour temperature. The collection comprises several sizes (S, M, L, XL) and various types of lights (pendent, floor, table, wall).

DESIGN

LUCIE KOLDOVA



MONA













The Whistle collection is, quite literally, a living reference to the work of glassmakers, as inspiration for the design was taken from the blowpipe, which in Czech is known as a glassmaker's whistle. The lucid body of the piece traces the silhouette of a cone of light, and a distinct spotlight with hand-pressed metal shield constitutes its imaginary heart. The overall shape and the naked cable winding its way up

DESIGN

through the body of the light define the character of its simplistic technical form. The collection comprises a suspension light in two sizes as well as a set of three lights.

From March 2018, Whistle is fitted with special integrated connectors developed by BROKIS to facilitate installation and cleaning.

LUCIE KOLDOVA



WHISTLE













NIGHT BIRDS



Inspired by the abandon and freedom of bird flight, the innovative Night Birds suspension lights impart poetic enchantment and unparalleled dynamism to any interior. Night Birds differ from the other collections in the unique technology applied in production, which involves melting glass into a mould and then bending it. The process makes it possible to instil delicate nuances in the shape of the wings and achieve a colouration of the glass that is different and wholly unique each time. The collection's

restraint and directness are underscored by the minimalist LED light source set in a fixture of lacquered and polished aluminium. The Night Birds collection comprises three lights with different wing attitudes depicting the various phases of bird flight. The lights come in white or dark glass as well as in BROKISGLASS, and there is also a new outdoor variant. Night Birds work best in large flocks. Now the metal components are also available in a black anodized finish.

DESIGN

BORIS KLIMEK





LIGHTLINE



In its every component, the Lightline collection is a celebration of glass as an artistic medium. The concept of a line of light is rooted in the varying characteristics of the material and its forms. The design employs the effect of light uniformly dispersed over a sandblasted surface, which in profile creates the impression of a luminous line.

DESIGN

The LED light source is embedded in the base beneath a metal and triplex opal glass shroud. The upper surface, sandblasted by hand, is treated with a special nano coating to prevent the accumulation of dust and smudges. The collection comprises four table lamps that cast a light of intimate character.

LUCIE KOLDOVA









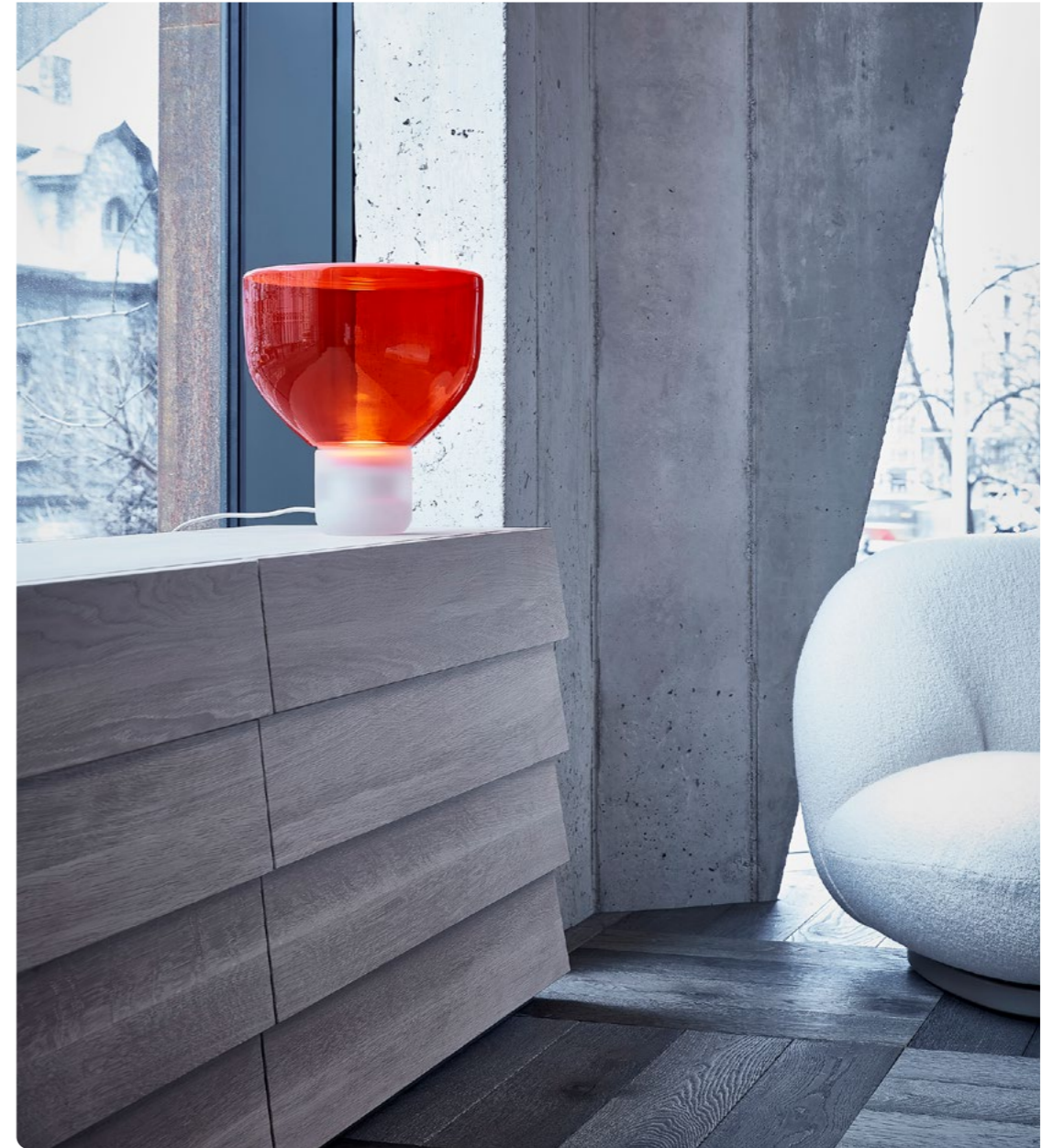

Knot, a collection of stately pendent lights, contrasts two dissimilar materials, two dissimilar notions: gentle curves in clear handblown glass against the austerity of coarse rope. The resulting design is striking, forthright, and dignified at the same time.

Full-bodied globes of varying shapes and sizes are penetrated by robust rope ending in the core design element of the collection – the knot – which seemingly pulls the bottom of the glass inward for a bemusing plastic effect. The LED light source is

mounted beneath an elegant hood made of stamped metal and protected from below by a handblown triplex opal diffuser. Another metal component serves to cap the end of the rope. The collection comprises lights of four different shapes in two sizes with a variety of colour options. There's also a romantic table light, which is now available in a version for exterior use as well. Now the metal components are available in an optional white powder finish.

DESIGN

CHIARAMONTE MARIN



KNOT











PURO



Puro is a boldly minimalistic variation on atmospheric pendent lights. Inspiration for the collection and its name come from the Spanish word for “cigar”, which also means “pure” and is a reference to the composition’s clean lines. The original design in the Puro collection creates an intriguing interplay between horizontal and vertical luminous cigar tubes levitating in space above simple bell lights. The diffused glow of the tubes combines with that of the bells to elicit a dynamic ambience, while the alternating gloss and matte finishes provide a degree of provocation. The first variations to appear were a bell light suspended beneath a single vertical tube and dual bell

lights suspended beneath a single horizontal tube. Multiple tubes can be combined to create amazing installations, such as a screen to divide space and evoke an intimate atmosphere bordering on scenography. The endless variability of the Puro collection gives rise to new lighting objects for any interior. The Puro family – Solo, Single, Spotlight, Eclectic, Contour, Sparkle, and Floor – is available in various sizes in either matte triplex opal or smoke grey glass. Puro have special integrated connectors developed by BROKIS for improved variability and ease of installation and cleaning.

DESIGN

LUCIE KOLDOVA

















MACARON



The Macaron table light pays homage to the beauty and complex structures of crystalline stone. Enclosed in opposing domes of delicate handblown glass, the stone becomes a moonscape afloat in its own cosmos. The light source casts its glow upward from the onyx base to energize the meandering chalcedony veins in the centre onyx plate and create a subtle and mesmerizing lighting effect. The concept is based on the principle of illuminating stone, and the name refers to the light's similarity in shape to the famed French meringue confection. Natural imperfections in the glass and the diversity

of structures in the stone make each light a unique original. The purity of the natural materials and the artisanship applied in processing them have given rise to a light of extraordinary ambience. Produced using traditional techniques, Macaron is characteristic of the distinctive and enduring aesthetic of the BROKIS brand. Macaron comes in three sizes – the largest of which also makes an attractive floor light – and in several glass colour options with either white or honey onyx. The collection offers an alternate version featuring a centre plate made of BROKISGLASS in combination with a wooden base.

DESIGN

LUCIE KOLDOVA









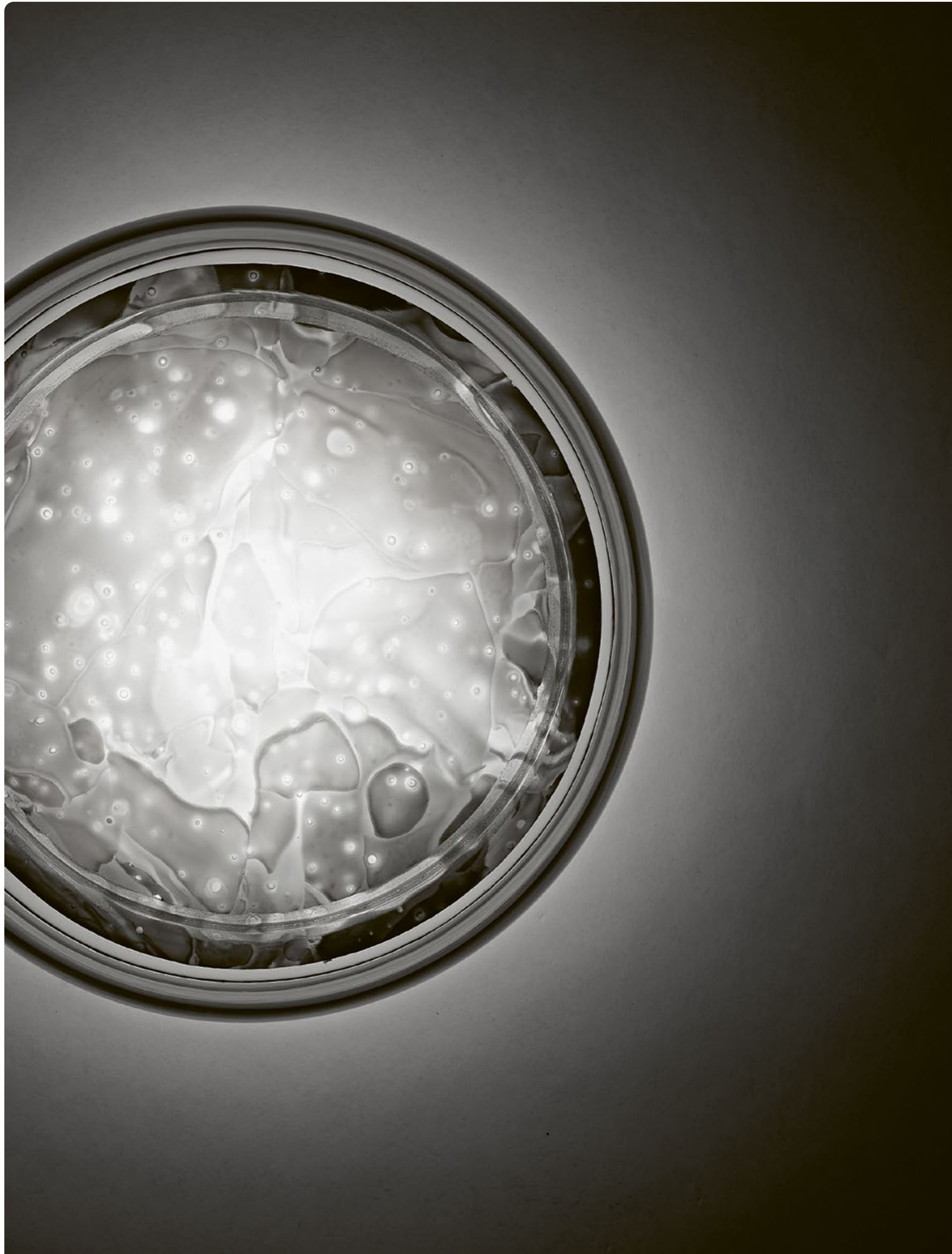



JACK O'LANtern

Light as a jewel of the home. A functional object in aesthetic elation, a sentinel of the evening and the night. The subtle levitating metal frame bears good tidings and a luminous pearl in the form of a handblown matte sphere. With inspiration taken from the carved pumpkin, Lucie Koldova's concept shows the way and becomes a building block in the house of light, beckoning passers-by to enter. This subtle and geometrically balanced light offers a wide variety of combinations. It can be hung

DESIGN

separately or in vertical lighting arrangements. In addition to the suspension variant, there is also a wall composition comprising five frames joined in a single module for up to five glass spheres, which rely on nothing more than gravity to stay in place. The table version combines the beauty of handblown acid-etched glass in smoke grey, light pink, or triplex opal with a metal frame and marble base. Sizes and versions: Wall (small), Pendant and Table (small and large).

LUCIE KOLDOVA











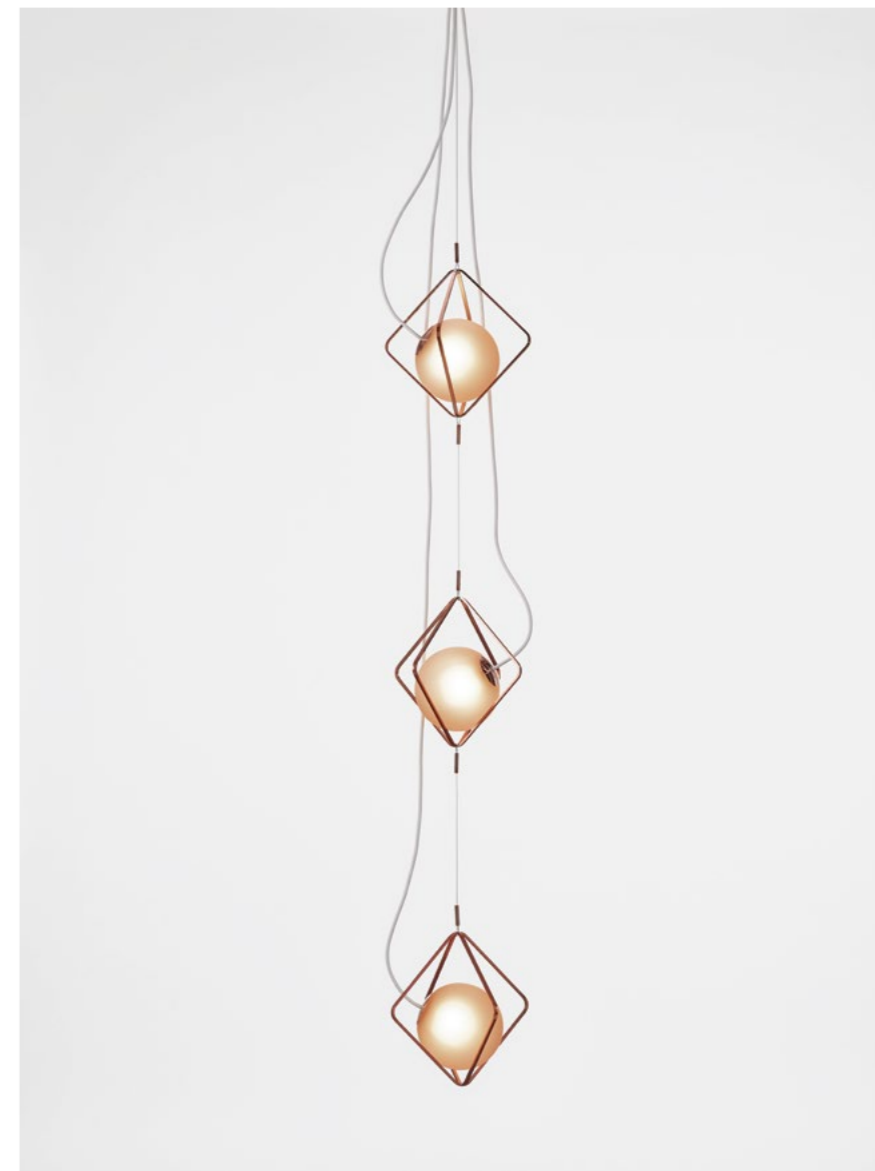

This large-format light with a matte core by designer Lucie Koldova embodies a gentle poetry, simplicity, purity, and balanced proportions. A key role is played by the inoculation of luminous bodies and their mutual interaction in space. The sophisticated design of a bubble suspended in

the centre of a large sphere evokes a sense of levitation. The outer glass is available in either transparent or smoke grey transparent with gloss finish; the inner glass in matte triplex opal, smoke grey transparent, red transparent, or light pink transparent. Big One lights come in two sizes.

DESIGN

LUCIE KOLDOVA



BIG ONE









IWY



Nature and its life-giving beauty and strength are the inspiration behind the unique lighting concept called Ivy. Just as the plant grows and climbs up the wall of a house, so too can Ivy expand into a variety of compositions. The collection features a special system of modular components for a highly innovative take on decorative lighting in both vertical and horizontal installations. The collection comprises metal components in combination with handblown glass. Branches come in five basic sizes, while there are three sizes of shades in matte light rose, triplex opal, or smoke

DESIGN

glass. The collection also offers an impressive floor light and intimate table lights. Elegant and precise in craftsmanship all the way down to the smallest detail, Ivy is a high-tech lighting concept ideally suited to project and residential applications. In household settings, for example, a single graceful branch can be hung above a dining table, or multiple branches can be used to create a curtain of light. The organic Ivy collection has many forms and rightfully holds its place in the realm of artistic, bespoke lighting solutions.

LUCIE KOLDOVA







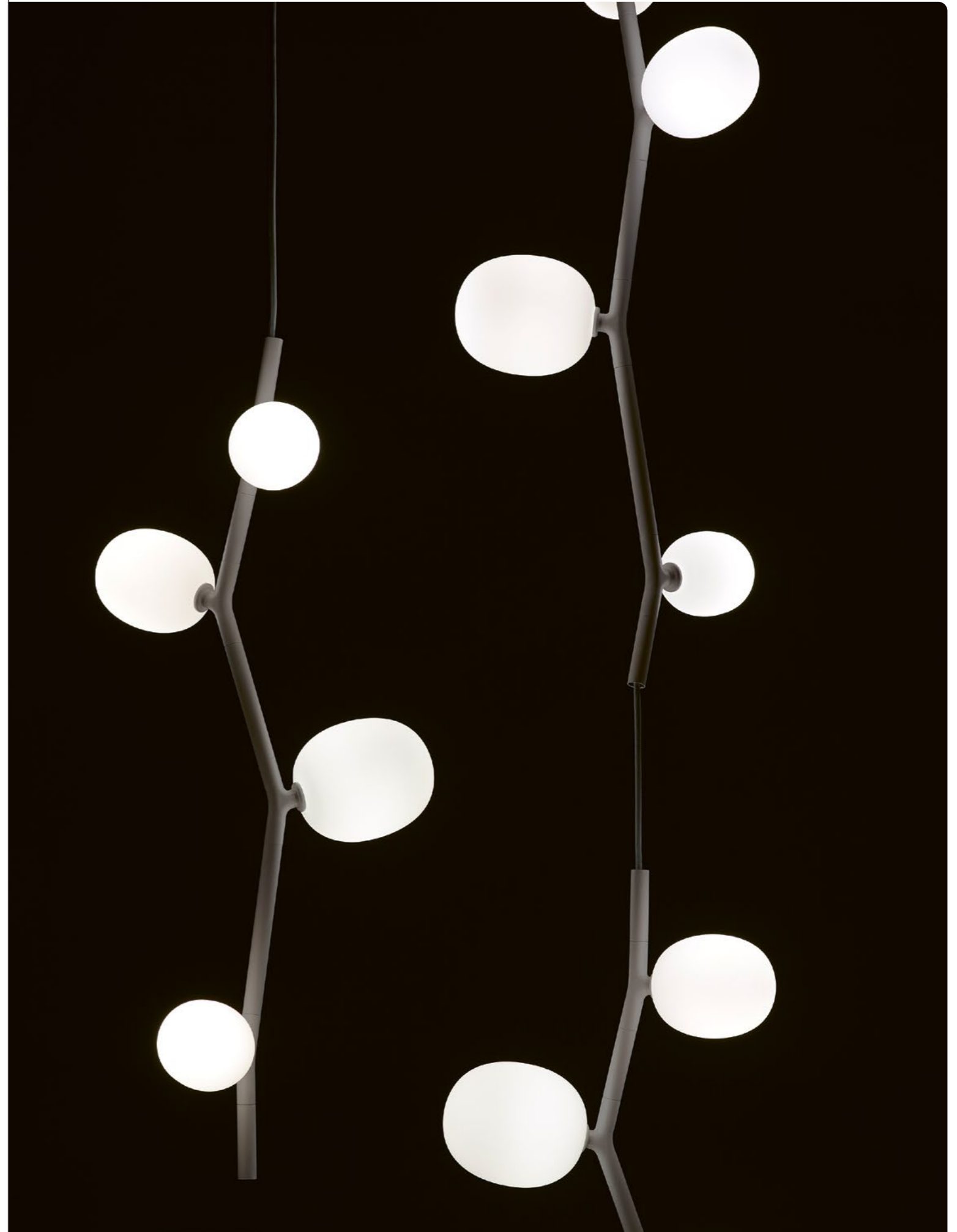





AWWA



In Japanese, the word “awa” is used to describe a bubble of air trapped within a liquid. The design of this delicate light was inspired by the notion of soft glass that has retained its shape after being inflated. The aim is to give the impression of a luminous ball

DESIGN

of air floating gently in space when viewed from below. Another special characteristic of the design is that the wood and metal parts appear to be made of glass, as if they were stoppers keeping the air from escaping.

FUMIE SHIBATA









BONBORI



The new Bonbori collection, which was created by world-renowned Japanese designer Fumie Shibata, is available in indoor and outdoor variants. The light is inspired by the traditional paper lamps that line the paths to shrines and temples during the annual paddy harvest festivals in Japan. In Japanese, the word “bonbori” not only denotes this traditional form of lighting, it also describes the soft light coming from within a snowy cave.

DESIGN

The gentle light of Bonbori pays tribute to a traditional Japanese lantern. Its skilfully crafted handblown glass and soft luminescence create a magical and festive ambience to be enjoyed as thoroughly in solitude as with family and friends. The new indoor light features special connectors developed by BROKIS that make it easy to unplug and move outside to a covered exterior space, for instance. Now also in a new wall variant.

FUMIE SHIBATA









The Sfera collection, one of the mainstays of the BROKIS portfolio, has been expanded with new shapes and sizes. Sfera lights are designed to meet the needs of projects and the architects and other professionals behind them. The sphere as a universal shape is now joined by an oval in two sizes also featuring a dramatically sheared top.

The prevailing characteristic of the Sfera project light is a clean cut across the top that serves as a platform for an elegant decagonal fixture. The timeless object casts a gentle light through handblown matte opal glass, which is attached to

a metal plate featuring a subtle multiangular detail. The original sphere now comes in eight sizes ranging from 150 to 600 mm and thus offers a considerable degree of variability in interior installations, while a practical hexagonal BROKIS connector makes it easy to install, maintain, and clean large sets of lights as well as rearrange them without having to alter the interior. The universal beauty and simplicity of the Sfera collection mean it can be used in any space and in any number, from a single light as an elegant accent to large bespoke compositions containing various sizes and shapes.

DESIGN

LUCIE KOLDOVA



SFERA









The Geometric collection has been expanded with a new table light. Geometric accentuates the aesthetic expression and structure of BROKISGLASS, which itself is remarkably distinctive. The collection is defined by basic geometric shapes that characterize the overall contours of the lights and instill them with a singular graphic element to achieve a striking contrast with the animate, almost sculptural makeup of the glass. The suspension components make up the glass geometric shapes, their edges rendered in black profiles. The circular and oval lights work well as solitary pieces, and multiples can also be arranged

DESIGN

in a sort of jigsaw puzzle, which in the hands of architects results in an endless variety of lighting combinations. The concept surpasses its primary function as a lighting fixture and opens the door to large-format blocks of light and other uncommon compositions. For even more expressive freedom and a truly bespoke lighting experience, clients can specify a different colour of glass in each of the two sections of a light. Resting against a sturdy cylindrical base, the new Geometric Table elicits a subtle aesthetic tension that amplifies the overall visual experience.

BORIS KLIMEK, LENKA DAMOVÁ



GEOMETRIC











The Planets collection is based on period lights and reflects the daily needs not only of customers but of architects and designers too. Thanks to a simple physical principle, the lights can be variably positioned in diverse arrangements. The use of weights and pulleys makes it possible to quickly adjust the height of the lights, a unique system that allows for several groupings to serve as individual sources of light in an interior, or as multiples of three different (or same) shapes to illuminate larger spaces. The counterweight is precisely calibrated to the specific weight of the light, so adjusting it is safe and easy. A round LED panel is situated beneath

DESIGN

a shade of matte glass, which conceals the internal parts and thus preserves the silhouette of the light. The metal components also come in a matte finish and are combined with a textile cord for a uniform look. The colour scheme is always monochromatic to underline the graphic character of the lights, and the glass shades are rendered in elementary geometric shapes – sphere, cone, and capsule. The Planets collection stands out with its remarkable versatility, offering a broader dimension in interior lighting with installations ranging from a single light to vast clouds of up to twelve lights.

VRTIŠKA & ŽÁK



PLANETS









The Orbis collection is based on a universal shape rendered in handblown smoke glass that has been abruptly severed across the top to accommodate an elegant multiangular metal fixture. Rich in ambience yet enticingly minimalist, these new atmospheric lights embody a sense of technicism. A diffusor conceals an LED panel within the fixture and softens the light as it radiates outwards from its source, while the multiangle serves to house a special

DESIGN

BROKIS connector engineered for easy installation and arrangement of grand lighting compositions. Additional variability is provided by a choice of subtle grey or brown smoke glass, with the metal fixture finished in a black powder coating that underscores the gloss of the transparent glass. These refined components come together to create an unmistakable interior charm well suited to large restaurant and hotel spaces as well as intimate private interiors.

LUCIE KOLDOVA

ORBIS







DOUBLE

Double, a new collection of pendent, table, and floor lights, is based on a shape consisting of two elements made from two different materials – glass and lightweight aluminium. These elements depend on one another to generate a unique and consonant form. The glass globe terminating in a metal ring provides a suggestive effect, with the handle on top alluding to the idea of transporting the light. In the pendent variant, which is available in three different shapes, the upper metal section with wire

rope seeks equilibrium in the scattered light and shadows as they pass through the lower metal ring and globe, the latter crafted from multiple layers of molten glass that are carefully scrutinized by the master glassmaker prior to blowing. The luminance of the LED light source is softened by an opal diffuser. By virtue of its scope, the Double collection is ideal for private interiors and works very well in large compositions and colour combinations.

DESIGN

LCM MARIN DESIGN STUDIO









**EXTERIOR
LIGHTS**

BONBORI OUTDOOR



archiproducts
DESIGN AWARDS
—
WINNER 2020

The very first outdoor lighting collection in the BROKIS portfolio, Bonbori was created by world-renowned Japanese designer Fumie Shibata, who took inspiration from the traditional paper lamps that line the paths to shrines and temples during the annual paddy harvest festivals in Japan. In Japanese, the word “bonbori” not only denotes this traditional form of lighting, it also describes the soft light coming from within a snowy cave. Manufactured in compliance with the IP44 rating for outdoor use, the light makes use of a simple stainless-steel base finished in an environmentally friendly weather-resistant powder coating. The easily

removable LED light source, which can withstand below-freezing temperatures, casts a gentle glow through a diffuser and laser-cut openings in the stainless steel. The likeness to the traditional bonbori lamp is achieved with an elegant handblown glass shade, an extraordinary piece crafted from multiple layers of carefully moulded glass. Whether in the garden, on the terrace, or in other outdoor settings, the soft, gentle light of Bonbori pays tribute to a Japanese tradition by creating a unique and festive ambience to be enjoyed as thoroughly in solitude as with family and friends.

DESIGN

FUMIE SHIBATA



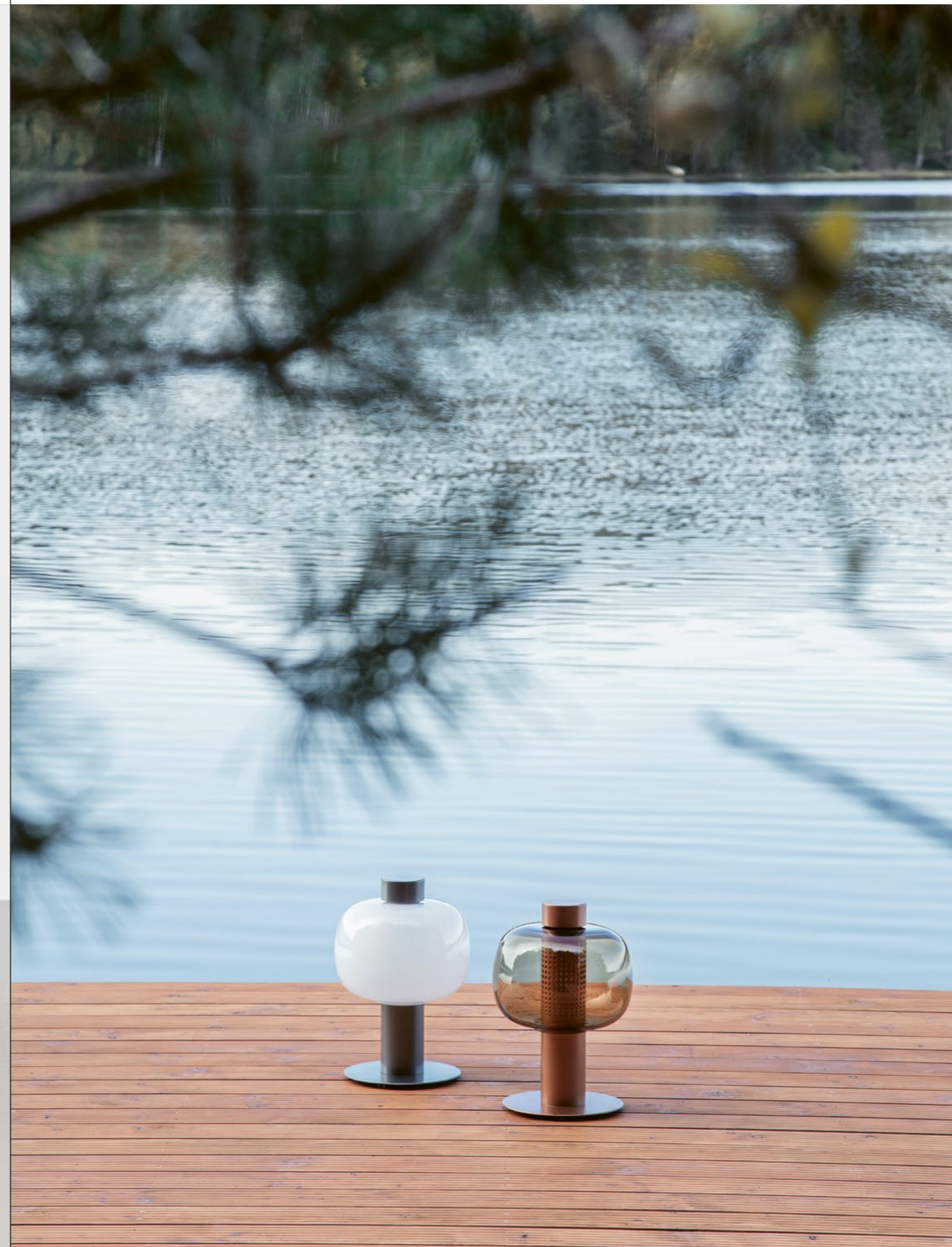



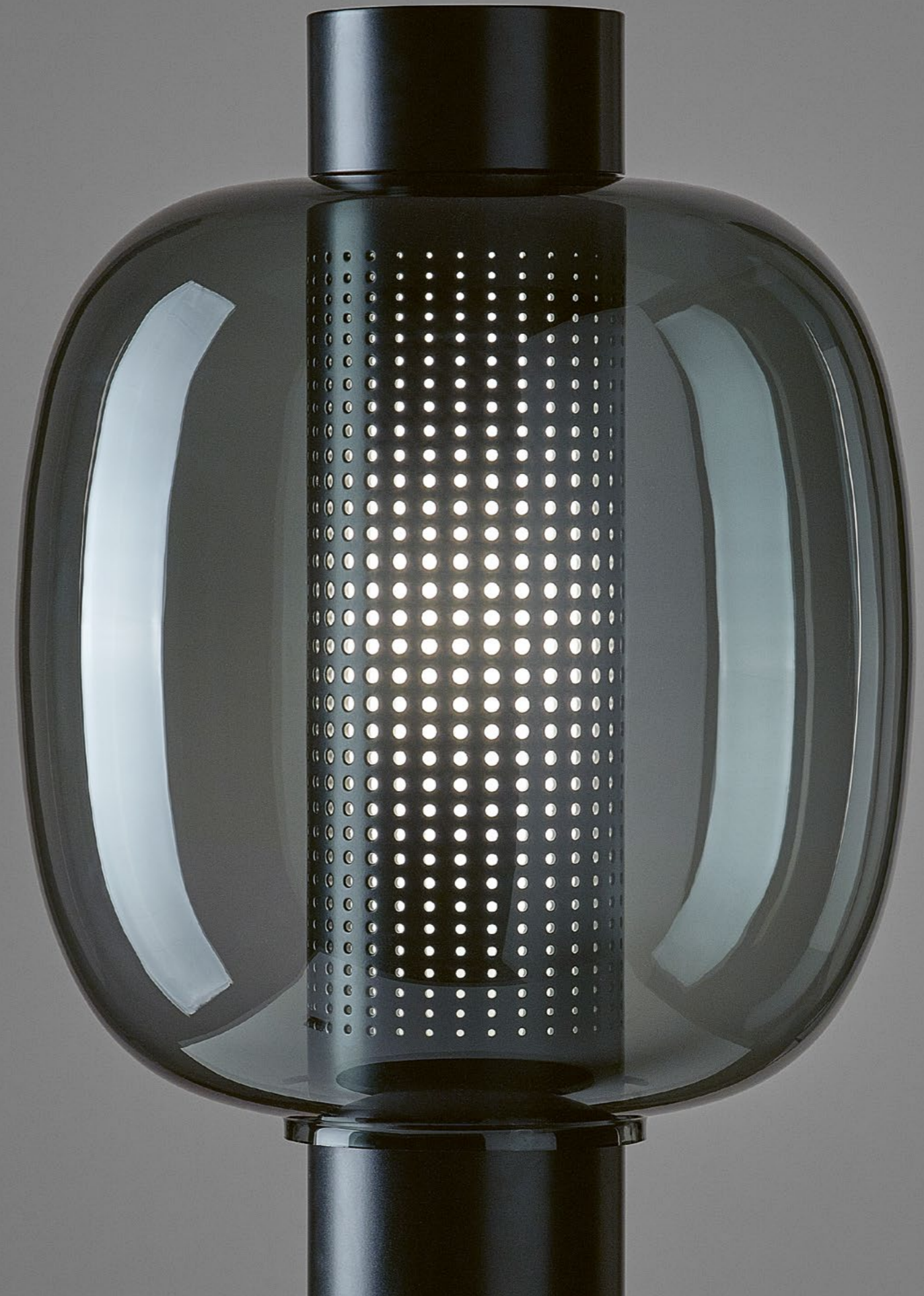



BONBORI WALL

The very first outdoor lighting collection in the BROKIS portfolio, Bonbori was created by world-renowned Japanese designer Fumie Shibata. This successful collection has now been expanded with wall-mounted lights based on the original smaller Bonbori lamp. The new Bonbori Wall comes in two variants, the first of which respects its traditional pedigree and is called Bonbori Wall Up. The second light is called Bonbori Wall Down and, as the name suggests, is a mirror image of the former. Both variants are well suited to interior and exterior installation. The Bonbori family

is inspired by the traditional paper lamps that line the paths to shrines and temples during the annual paddy harvest festivals in Japan. In Japanese, the word 'bonbori' not only denotes this traditional form of lighting, but it also describes the soft light coming from within a snowy cave. The gentle light of Bonbori pays tribute to a traditional Japanese lantern. Its skilfully crafted handblown glass and soft luminescence create a magical and festive ambience to be enjoyed as thoroughly in solitude as with family and friends.

DESIGN

FUMIE SHIBATA





Now the iconic Shadows collection by Lucie Koldova and Dan Yeffet is ready to illuminate exterior settings. Shadows is a take on the famed, timeless lights found in French ateliers, and its typology pays tribute to that legacy. Identical in appearance to the original Shadows, the new collection complies with the IP54 rating for exterior use: the handmade wooden body used in the indoor lights has been replaced with a two-piece weatherproof dural body, its subtle form and finish accentuated by a recessed

LED light source. Special integrated connectors developed by BROKIS make it easy to install the lights in large sets as well as maintain and clean them. The lights can be arranged in diverse compositions based on the needs of the customer or used as solitary exterior lighting elements. The combination of handblown glass and classic shapes has given rise to lighting of unageing elegance whose singular ambience is no longer restricted to the interior.

DESIGN

LUCIE KOLDOVA, DAN YEFFET



SHADOWS EXTERIOR









NIGHT BIRDS EXTERIOR

The Night Birds collection by Boris Klimek is now available in a version suitable for exterior use. Night Birds Exterior are identical to the original indoor collection, which was inspired by the freedom and abandon of bird flight. In order to withstand the whims of the weather, the lights have been modified to comply with the IP54 rating for exterior use, namely by enlarging and weatherproofing the positionable hand-polished dural fixture, which conceals

a sophisticated balancing mechanism and the subtle LED light source. The bigger, more robust metal fixture also allows for a greater selection of light sources. Like the original Night Birds collection, Night Birds Exterior offers three different lights, each with a different wing position, which come in either white or dark (nearly black) variants. From now on, Night Birds are as at home in the elements or the dark of night as they are in the comfort of the indoors.

DESIGN

BORIS KLIMEK







**BATTERY-POWERED
LIGHTS**



KNOT BATTERY

Knot, a collection of stately pendent lights that appose two dramatically dissimilar materials, has now been expanded with a portable outdoor variant. The original Knot collection features full-bodied globes of varying shapes and sizes penetrated by robust cords that seemingly pull the glass inward for a bemusing plastic effect. Knot Battery provides the perfect anchor for the lofty pendants in this collection typified by its use of strikingly disparate materials. The LED light source is cradled in a handsome bottom piece, which, like the cord end cap,

DESIGN

is fashioned from refined metal. Knot Battery is IP44 compliant for outdoor use, thus its charm is not confined to only the interior. Charging is by means of a convenient magnetic connector in the lower part of the light. Knot Battery is a sophisticated and flexible light that provides up to six hours of use on a single charge, which makes it ideal not only for lighting outdoor spaces but also enhancing existing lighting. Thanks to its portability, Knot Battery is well suited to daily use and for adding a special touch to social events. Now also in a smaller variant.

CHIARAMONTE MARIN





Ivy Table Battery by Lucie Koldova is the latest addition to the already substantial Ivy family, which is inspired by nature and its life-giving beauty. The new battery-powered table version is somewhat smaller than the original Ivy Table, which makes it easy to move from one place to another and create unique lighting experiences anywhere, anytime. Although it is not protected from direct contact with water, its portability and robust build quality make it suitable for use in outdoor settings. Ivy Table Battery is touch operated and has three brightness settings

DESIGN

for just the right amount of light at a given moment. The lithium battery pack powers the light for up to six hours, and charging is by means of induction or a USB connector. The collection comprises a metal frame and handblown glass shades in matte light rose, triplex opal, or smoke grey. The new Ivy Table Battery represents a graceful and flexible lighting object for restaurants and hotels, where it can be unrestrainedly combined in luminous landscapes that change in step with the space around them.

LUCIE KOLDOVA

IVY BATTERY







The Italian LCM MARIN design studio has created a new outdoor collection for BROKIS called Dome Nomad, which takes inspiration from the domes of Venice. Dome Nomad is an outdoor lamp whose dome shape represents eternity and the vastness of the celestial vault. The dome shape of the hand-blown glass section comes in one of two variants: smooth clear glass or wavy clear glass. Dome Nomad is a new portable rechargeable outdoor lamp, the lines of which are a nod towards Italian architecture. The gentle light passes through an opal diffuser and the namesake glass shade. The Dome Nomad collection complies with the IP44 safety

and technological standards for outdoor lighting. The simple design features refined stainless steel finished in an environmentally friendly powder coating for outstanding resistance to the elements. The LED source can withstand freezing temperatures. Multiple layers of molten glass are used to make the glass shade, and each one is subjected to the utmost scrutiny by the master glassmakers before being blown into the mould. Dome Nomad can be placed on a table or floor and is also suitable for hanging. It is a design experience that adds a special charm both to gardens and terraces as well as to interior spaces.

DESIGN

LCM MARIN DESIGN STUDIO

DOME NOMAD



archiproducts
DESIGN AWARDS
—
WINNER 2019







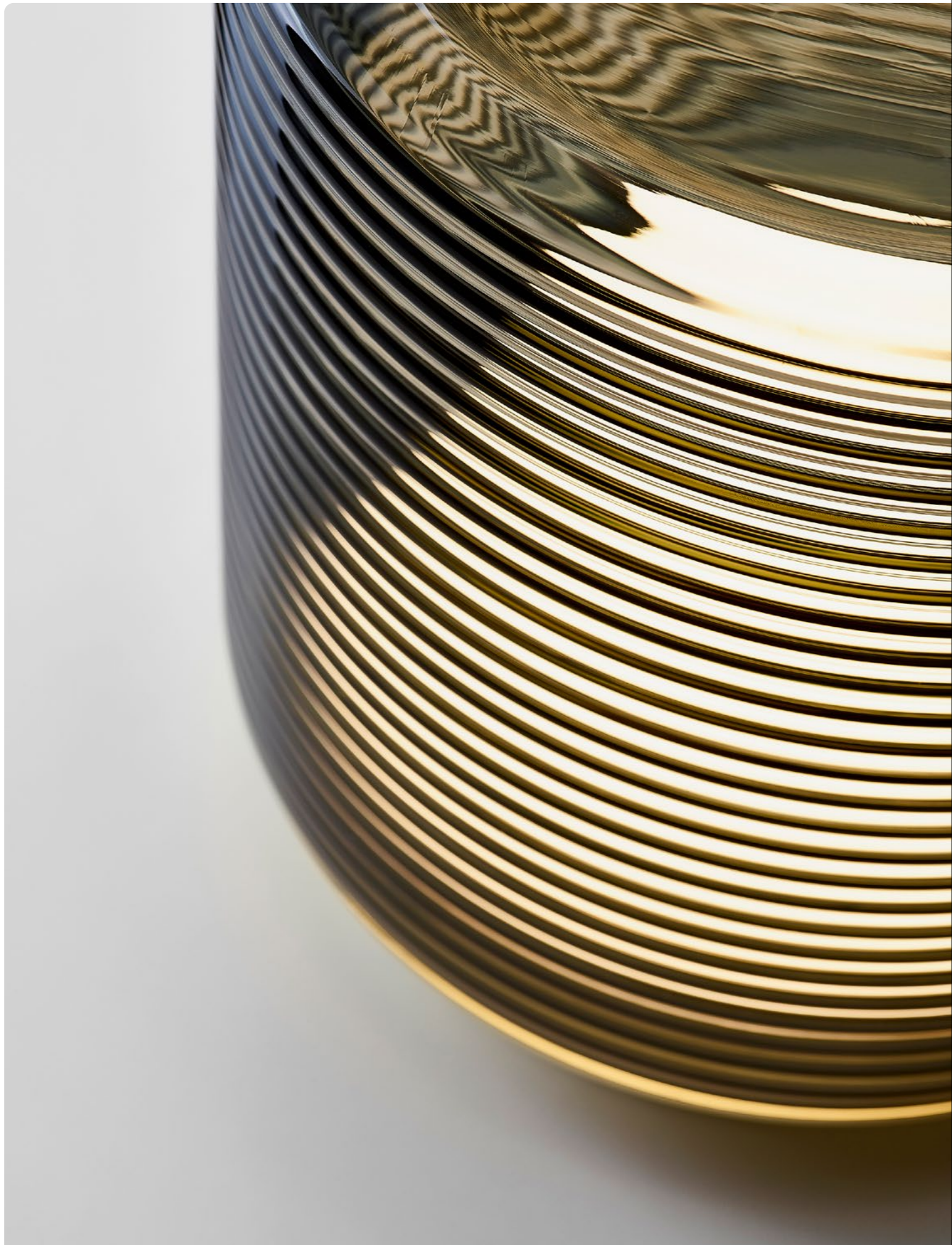



SFERA PORTABLE

Sfera Portable is a new rechargeable outdoor light that comes in two sizes. It is one of the latest additions to the BROKIS outdoor lighting portfolio. Sfera Portable is based on the idea of a small sphere of light set within a poured concrete base with the same subtle multiangular detail used throughout the Sfera family. The delicate sphere of handblown matte or gloss glass resides beneath a stainless-steel hoop, which serves as a handle for moving the light from one place to another. The concrete base houses not only the charging module but also a sensitive touch dimmer with which to adjust the brightness. Sfera Portable is fitted

DESIGN

with an LED light source with diffuser and meets the safety and technological standards of the IP44 rating for outdoor use. The sphere as a timeless and perfect shape whose allure never ceases to capture the imagination. Handblown glass anchored in a raw, almost brutalist concrete base is an excellent match for modern architecture, but it can also be used to great effect when set in contrast with historical architecture. Sfera Portable is a stylish atmospheric lighting object designed for both outdoor and indoor use. Thanks to its simple construction, the light can be easily picked up and moved to change the ambience of any space.

LUCIE KOLDOVA









ACCESSORIES



MUFFINS CANDLEHOLDER



Muffins Candleholder is a captivating experience. With its subtle lines in glass, solid wood base, and masterful craftsmanship, not only will the Muffins Candleholder reveal something of your sense for

DESIGN

detail and exquisite design, but it will also lend your room a festive air any time of the day or night. The Muffins Candleholder is part of the iconic Muffins lighting collection, an emblem of the BROKIS brand.

LUCIE KOLDOVA, DAN YEFFET





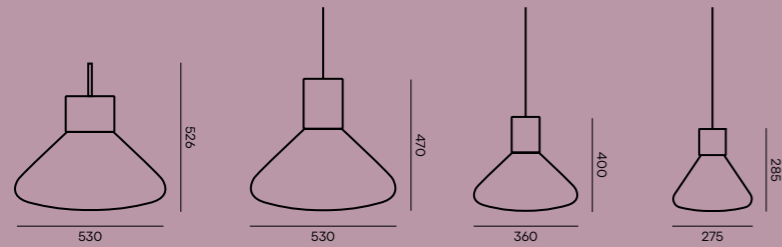

PC852 PC851 PC865 PC986

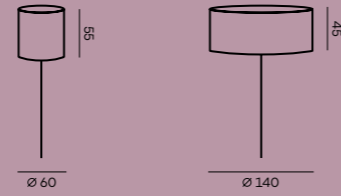

Canopy for PC851, PC865, PC986
Optional on request

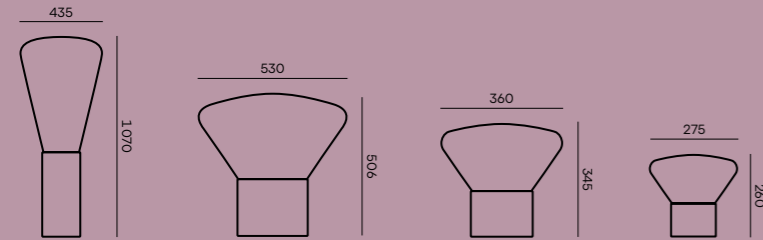

PC853 PC850 PC849 PC910

p. 21 | PH5328
PC849 (CGC2753, CGSU66, CCS2765, CECL519, CEB784)
 GLASS COLOUR: aubergine – transparent glass
 GLASS SURFACE: glossy surface
 BODY FINISH: high gloss – conservative grey
 CABLE COLOUR: textile cable – black
 RECOMMENDED BULBS: 230V, LED, E27, 6W, 2200K, 350lm, RA90, 360°, DIM
PC850 (CGC516, CGSU66, CCS2764, CECL519, CEB784))
 GLASS COLOUR: smoke grey – transparent glass
 GLASS SURFACE: glossy surface
 BODY FINISH: high gloss – cheeky raspberry
 CABLE COLOUR: textile cable – black
 RECOMMENDED BULBS: 230V, LED, E27, 6W, 2200K, 350lm, RA90, 360°, DIM

p. 22—23 | PH956
PC910 (CGC23, CGSU66, CCS757, CECL519, CEB781)
 GLASS COLOUR: transparent glass
 GLASS SURFACE: glossy surface
 BODY FINISH: American walnut – natural waxed
 CABLE COLOUR: textile cable – black
 RECOMMENDED BULBS: 230V, LED, E14, 4.7W, 2200K, 280lm, RA90, 360°, DIM
PC865 (CGC23, CGSU66, CCS757, CCSC842, CECL519, CEB784)
 GLASS COLOUR: transparent glass
 GLASS SURFACE: glossy surface
 BODY FINISH: American walnut – natural waxed,
 CANOPY FINISH: American walnut – natural waxed
 CABLE COLOUR: textile cable – black
 RECOMMENDED BULBS: 230V, LED, E27, 6W, 2200K, 350lm, RA90, 360°, DIM
PC849—PC852 (CGC23, CGSU66, CCS757, CECL519, CEB784)
 GLASS COLOUR: transparent glass
 GLASS SURFACE: glossy surface
 BODY FINISH: American walnut – natural waxed
 CABLE COLOUR: textile cable – black
 RECOMMENDED BULBS: 230V, LED, E27, 6W, 2200K, 350lm, RA90, 360°, DIM
PC849—PC853—PC850 (CGC516, CGSU66, CCS757, CECL519, CEB784)
 GLASS COLOUR: smoke grey – transparent glass
 GLASS SURFACE: glossy surface
 BODY FINISH: American walnut – natural waxed
 CABLE COLOUR: textile cable – black
 RECOMMENDED BULBS: 230V, LED, E27, 6W, 2200K, 350lm, RA90, 360°, DIM

PC851 (CGC516, CGSU66, CCS757, CCSC842, CECL519, CEB784)
 GLASS COLOUR: smoke grey – transparent glass
 GLASS SURFACE: glossy surface
 BODY FINISH: American walnut – natural waxed,
 CANOPY FINISH: American walnut – natural waxed
 CABLE COLOUR: textile cable – black
 RECOMMENDED BULBS: 230V, LED, E27, 6W, 2200K, 350lm, RA90, 360°, DIM
PC910 (CGC516, CGSU66, CCS757, CECL519, CEB781)
 GLASS COLOUR: smoke grey – transparent glass
 GLASS SURFACE: glossy surface
 BODY FINISH: American walnut – natural waxed
 CABLE COLOUR: textile cable – black
 RECOMMENDED BULBS: 230V, LED, E14, 4.7W, 2200K, 280lm, RA90, 360°, DIM

p. 24 | PH1361
PC850—PC853 (CGC516, CGSU66, CCS592, CECL519, CEB784)
 GLASS COLOUR: smoke grey – transparent glass
 GLASS SURFACE: glossy surface
 BODY FINISH: European oak – stained black
 CABLE COLOUR: textile cable – black
 RECOMMENDED BULBS: 230V, LED, E27, 6W, 2200K, 350lm, RA90, 360°, DIM

p. 25 | PH943
PC849—PC850 (CGC516, CGSU66, CCS518, CECL520, CEB784)
 GLASS COLOUR: smoke grey – transparent glass
 GLASS SURFACE: glossy surface
 BODY FINISH: European oak – natural waxed
 CABLE COLOUR: textile cable – dark grey
 RECOMMENDED BULBS: 230V, LED, E27, 6W, 2200K, 350lm, RA90, 360°, DIM
PC910 (CGC516, CGSU66, CCS518, CECL520, CEB781)
 GLASS COLOUR: smoke grey – transparent glass
 GLASS SURFACE: glossy surface
 BODY FINISH: European oak – natural waxed
 CABLE COLOUR: textile cable – dark grey
 RECOMMENDED BULBS: 230V, LED, E14, 4.7W, 2200K, 280lm, RA90, 360°, DIM

p. 26—27 | PH946
PC852 (CGC516, CGSU66, CCS680, CECL521, CEB784)
 GLASS COLOUR: smoke grey – transparent glass
 GLASS SURFACE: glossy surface
 BODY FINISH: European oak – stained white

CABLE COLOUR: textile cable – white
 RECOMMENDED BULBS: 230V, LED, E27, 6W, 2200K, 350lm, RA90, 360°, DIM
PC910 (CGC38, CGSU66, CCS680, CECL521, CEB781)
 GLASS COLOUR: opaline – transparent glass
 GLASS SURFACE: glossy surface
 BODY FINISH: European oak – stained white
 CABLE COLOUR: textile cable – white
 RECOMMENDED BULBS: 230V, LED, E14, 4.7W, 2200K, 280lm, RA90, 360°, DIM
PC849 (CGC39, CGSU66, CCS680, CECL521, CEB784)
 GLASS COLOUR: triplex opal
 GLASS SURFACE: glossy surface
 BODY FINISH: European oak – stained white
 CABLE COLOUR: textile cable – white
 RECOMMENDED BULBS: 230V, LED, E27, 6W, 2200K, 350lm, RA90, 360°, DIM
PC849—PC853 (CGC23, CGSU66, CCS680, CECL521, CEB784)
 GLASS COLOUR: transparent glass
 GLASS SURFACE: glossy surface
 BODY FINISH: European oak – stained white
 CABLE COLOUR: textile cable – white
 RECOMMENDED BULBS: 230V, LED, E27, 6W, 2200K, 350lm, RA90, 360°, DIM
PC850 (CGC38, CGSU66, CCS680, CECL521, CEB784)
 GLASS COLOUR: opaline – transparent glass
 GLASS SURFACE: glossy surface
 BODY FINISH: European oak – stained white
 CABLE COLOUR: textile cable – white
 RECOMMENDED BULBS: 230V, LED, E27, 6W, 2200K, 350lm, RA90, 360°, DIM

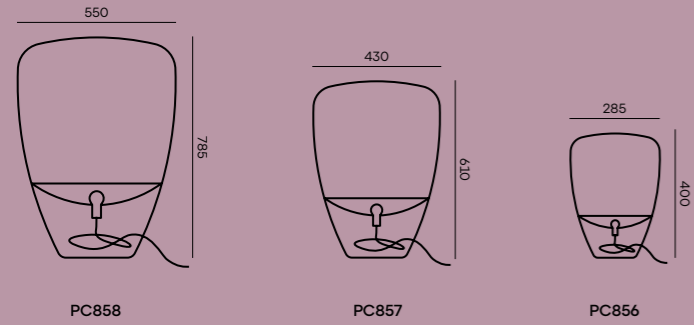

p. 29 | PH21
PC856 (CGC538, CGSU66, CCS69, CECL519, CEB925)
 GLASS COLOUR: smoke brown – transparent glass
 GLASS SURFACE: glossy surface
 BODY FINISH: brass
 CABLE COLOUR: textile cable – black
 RECOMMENDED BULBS: 230V, LED, E14, 4.7W, 2200K, 280lm, RA90, 360°, DIM

p. 30—31 | PH680
PC856 (CGC516, CGSU66, CCS960, CECL519, CEB925)
 GLASS COLOUR: smoke grey – transparent glass
 GLASS SURFACE: glossy surface
 BODY FINISH: chrome brushed
 CABLE COLOUR: textile cable – black
 RECOMMENDED BULBS: 230V, LED, E14, 4.7W, 2200K, 280lm, RA90, 360°, DIM
PC856 (CGC538, CGSU66, CCS69, CECL519, CEB925)
 GLASS COLOUR: smoke brown – transparent glass
 GLASS SURFACE: glossy surface
 BODY FINISH: brass
 CABLE COLOUR: textile cable – black
 RECOMMENDED BULBS: 230V, LED, E14, 4.7W, 2200K, 280lm, RA90, 360°, DIM
PC856 (CGC23, CGSU66, CCS275, CECL519, CEB925)
 GLASS COLOUR: transparent glass
 GLASS SURFACE: glossy surface
 BODY FINISH: chrome
 CABLE COLOUR: textile cable – black
 RECOMMENDED BULBS: 230V, LED, E14, 4.7W, 2200K, 280lm, RA90, 360°, DIM

p. 32 | PH689
PC856 (CGC23, CGSU66, CCS584, CECL519, CEB925)
 GLASS COLOUR: transparent glass
 GLASS SURFACE: glossy surface
 BODY FINISH: copper
 CABLE COLOUR: textile cable – black
 RECOMMENDED BULBS: 230V, LED, E14, 4.7W, 2200K, 280lm, RA90, 360°, DIM
PC857 (CGC23, CGSU66, CCS584, CECL519, CEB782)
 GLASS COLOUR: transparent glass
 GLASS SURFACE: glossy surface
 BODY FINISH: copper
 CABLE COLOUR: textile cable – black
 RECOMMENDED BULBS: 230V, LED, E27, 6W, 2200K, 400lm, RA90, 360°, DIM

p. 33 | PH691
2×PC856 (CGC23, CGSU66, CCS584, CECL519, CEB925)
 GLASS COLOUR: transparent glass
 GLASS SURFACE: glossy surface
 BODY FINISH: copper
 CABLE COLOUR: textile cable – black
 RECOMMENDED BULBS: 230V, LED, E14, 4.7W, 2200K, 280lm, RA90, 360°, DIM
PC858 (CGC23, CGSU66, CCS584, CECL519, CEB782)
 GLASS COLOUR: transparent glass
 GLASS SURFACE: glossy surface
 BODY FINISH: copper
 CABLE COLOUR: textile cable – black
 RECOMMENDED BULBS: 230V, LED, E27, 6W, 2200K, 400lm, RA90, 360°, DIM

p. 34—35 | PH1179
PC856 (CGC516, CGSU66, CCS582, CECL519, CEB925)
 GLASS COLOUR: smoke grey – transparent glass
 GLASS SURFACE: glossy surface
 BODY FINISH: black
 CABLE COLOUR: textile cable – black
 RECOMMENDED BULBS: 230V, LED, E14, 4.7W, 2200K, 280lm, RA90, 360°, DIM
PC858 (CGC516, CGSU66, CCS584, CECL519, CEB782)
 GLASS COLOUR: smoke grey – transparent glass
 GLASS SURFACE: glossy surface
 BODY FINISH: copper
 CABLE COLOUR: textile cable – black
 RECOMMENDED BULBS: 230V, LED, E27, 6W, 2200K, 400lm, RA90, 360°, DIM
PC856 (CGC516, CGSU66, CCS582, CECL519, CEB925)
 GLASS COLOUR: smoke grey – transparent glass
 GLASS SURFACE: glossy surface
 BODY FINISH: copper
 CABLE COLOUR: textile cable – black
 RECOMMENDED BULBS: 230V, LED, E14, 4.7W, 2200K, 280lm, RA90, 360°, DIM
PC857 (CGC516, CGSU66, CCS582, CECL519, CEB782)
 GLASS COLOUR: smoke grey – transparent glass
 GLASS SURFACE: glossy surface
 BODY FINISH: black
 CABLE COLOUR: textile cable – black
 RECOMMENDED BULBS: 230V, LED, E27, 6W, 2200K, 400lm, RA90, 360°, DIM

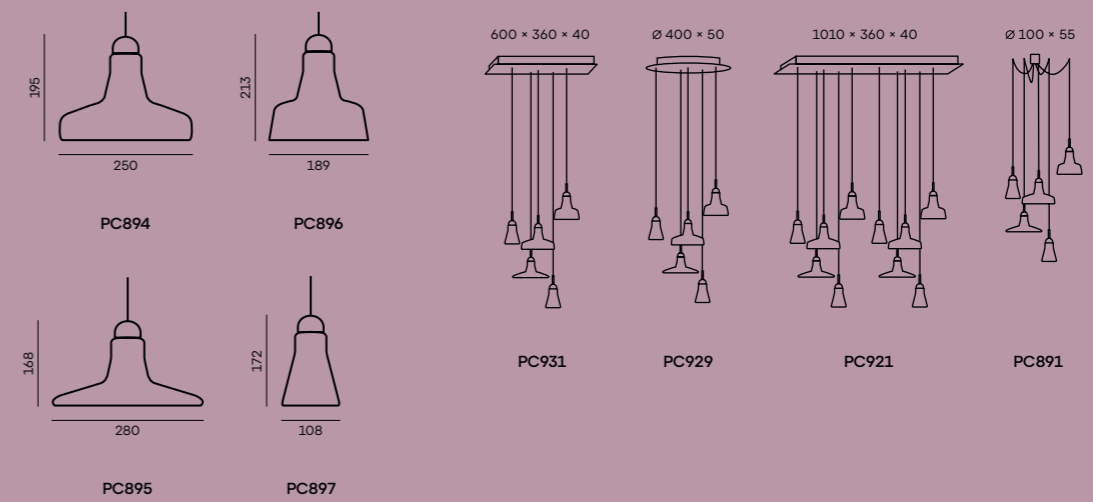

SHADOWS XL

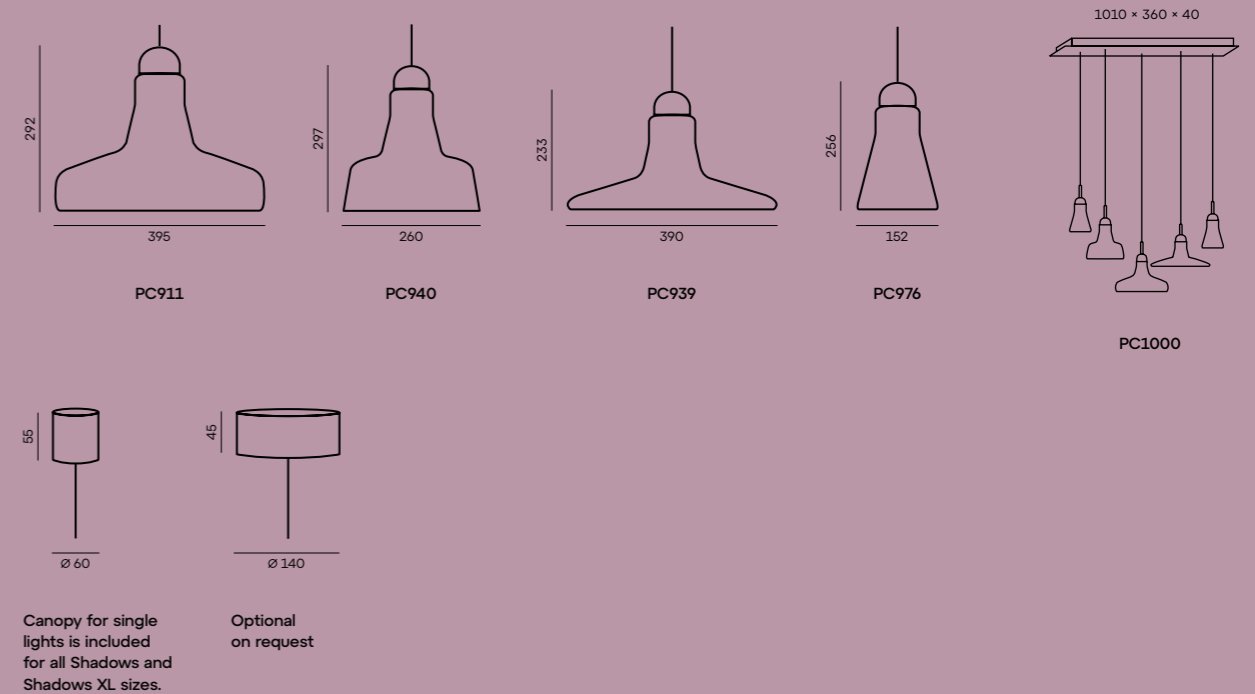

p. 37 | PH1620

PC891 (CCSC839)

CANOPY FINISH: European oak – stained black

2×PC897—PC894—PC895—PC896
(CGC516, CGSU66, CCS592, CECL519, CEB373)

GLASS COLOUR: smoke grey – transparent glass

GLASS SURFACE: glossy surface

BODY FINISH: European oak – stained black

CABLE COLOUR: textile cable – black

RECOMMENDED BULBS: 230V, GU10, 5W, 2700K,
336lm, RA90, 60°, DIM

p. 38 | PH1071

PC929 (CCSC618)

CANOPY FINISH: metal – white matte

powder coating

PC895—2×PC897—PC896—PC894**(CGC38, CGSU66, CCS657, CECL521, CEB373)**

GLASS COLOUR: opaline – transparent glass

GLASS SURFACE: glossy surface

BODY FINISH: European oak – untreated

CABLE COLOUR: textile cable – white

RECOMMENDED BULBS: 230V, GU10, 5W, 2700K,
336lm, RA90, 60°, DIM

p. 39 | PH6861

2×PC895—PC894—PC896—PC897**(CGC38, CGSU66, CCS518, CCSC841,****CECL521, CEB373)**

GLASS COLOUR: opaline – transparent glass

GLASS SURFACE: glossy surface

BODY FINISH: European oak – natural waxed

CANOPY FINISH: European oak – natural waxed

CABLE COLOUR: textile cable – white

RECOMMENDED BULBS: 230V, GU10, 5W, 2700K,
336lm, RA90, 60°, DIM

p. 40 | PH1637

PC894—PC896—PC895—PC897**(CGC602, CGSU67, CCS592, CCSC839,****CECL519, CEB373)**

GLASS COLOUR: black – transparent glass

GLASS SURFACE: acid-etched outside surface

BODY FINISH: European oak – stained black

CANOPY FINISH: European oak – stained black

CABLE COLOUR: textile cable – black

RECOMMENDED BULBS: 230V, GU10, 5W, 2700K,
336lm, RA90, 60°, DIM

p. 41 | PH1369

PC897—PC894—PC896—PC895**(CGC602, CGSU66, CCS592, CECL519, CEB373)**

GLASS COLOUR: black – transparent glass

GLASS SURFACE: glossy surface

BODY FINISH: European oak – stained black

CABLE COLOUR: textile cable – black

RECOMMENDED BULBS: 230V, GU10, 5W, 2700K,
336lm, RA90, 60°, DIM

p. 42—43 | PH1637

PC921 (CCSC619)

CANOPY FINISH: metal – black matte

powder coating

PC894—PC895—PC896—PC897**(CGC602, CGSU66, CCS592, CECL519, CEB373)**

GLASS COLOUR: black – transparent glass

GLASS SURFACE: glossy surface

BODY FINISH: European oak – stained black

CABLE COLOUR: textile cable – black

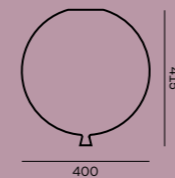
RECOMMENDED BULBS: 230V, GU10, 5W, 2700K,
336lm, RA90, 60°, DIM

PC876

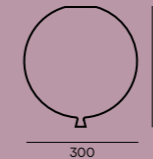

PC877

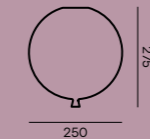

PC878

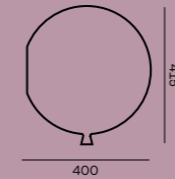

PC879

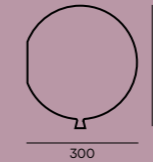

PC880

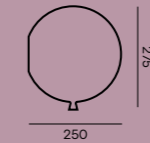

PC881

p. 45 | PH896

PC878 (CGC39, CGSU881, CCS620, CEE778)

GLASS COLOUR: triplex opal

GLASS SURFACE: acid-etched both side surface

BODY FINISH: iron chromate – silver

END CAPS: light switch – black

PC878 (CGC30, CGSU881, CCS620, CEE778)

GLASS COLOUR: light pink – triplex opal

GLASS SURFACE: acid-etched both side surface

BODY FINISH: iron chromate – silver

END CAPS: light switch – black

PC878 (CGC617, CGSU881, CCS620, CEE778)

GLASS COLOUR: grey – triplex opal

GLASS SURFACE: acid-etched both side surface

BODY FINISH: iron chromate – silver

END CAPS: light switch – black

p. 46 | PH1350

PC876 (CGC39, CGSU881, CCS620, CEE777)

GLASS COLOUR: triplex opal

GLASS SURFACE: acid-etched both side surface

BODY FINISH: iron chromate – silver

END CAPS: light switch – white

p. 47 | PH6553

PC878 (CGC617, CGSU881, CCS620, CEE777)

GLASS COLOUR: grey – triplex opal

GLASS SURFACE: acid-etched both side surface

BODY FINISH: iron chromate – silver

END CAPS: light switch – white

p. 48—49 | PH1348

PC877—PC878**(CGC39, CGSU66, CCS620, CEE777)**

GLASS COLOUR: triplex opal

GLASS SURFACE: glossy surface

BODY FINISH: iron chromate – silver

END CAPS: light switch – white

PC878—PC876**(CGC47, CGSU66, CCS620, CEE777)**

GLASS COLOUR: yellow – triplex opal

GLASS SURFACE: glossy surface

BODY FINISH: iron chromate – silver

END CAPS: light switch – white

PC876—PC877**(CGC617, CGSU66, CCS620, CEE777)**

GLASS COLOUR: grey – triplex opal

GLASS SURFACE: glossy surface

BODY FINISH: iron chromate – silver

END CAPS: light switch – white

p. 50 | PH1349

PC881 (CGC30, CGSU66, CCS620, CEE777)

GLASS COLOUR: light pink – triplex opal

GLASS SURFACE: glossy surface

BODY FINISH: iron chromate – silver

END CAPS: light switch – white

PC879—PC881**(CGC580, CGSU66, CCS620, CEE777)**

GLASS COLOUR: orange – triplex opal

GLASS SURFACE: glossy surface

BODY FINISH: iron chromate – silver

END CAPS: light switch – white

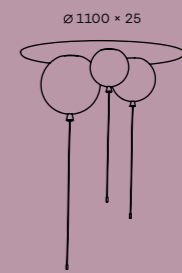

PC1001

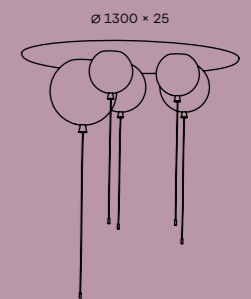

PC1002

p. 51 | PH899

PC1002 (CCSC887)

CANOPY FINISH: MDF canopy – white

PC876 (CGC617, CGSU66, CCS620, CEE778)

GLASS COLOUR: grey – triplex opal

GLASS SURFACE: glossy surface

BODY FINISH: iron chromate – silver

END CAPS: light switch – black

PC877—2×PC878**(CGC39, CGSU66, CCS620, CEE778)**

GLASS COLOUR: triplex opal

GLASS SURFACE: glossy surface

BODY FINISH: iron chromate – silver

END CAPS: light switch – black

PC877 (CGC580, CGSU66, CCS620, CEE778)

GLASS COLOUR: orange – triplex opal

GLASS SURFACE: glossy surface

BODY FINISH: iron chromate – silver

END CAPS: light switch – black

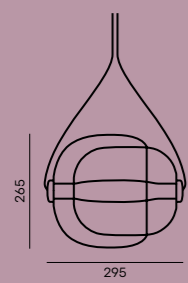

PC937

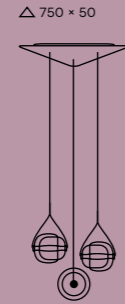
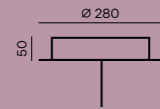

PC943

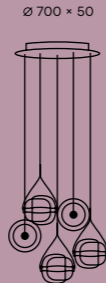

PC966

p. 53 | PH1240

PC937 (CGC23, CGSU66, CGCI685, CGSUI905, CCS1948, CCSC619, CECL519, LEDS1945)

GLASS COLOUR: transparent glass
GLASS SURFACE: glossy surface
INNER GLASS FINISH: acid-etched both side surface
BODY FINISH: black anodized
CANOPY FINISH: metal – black matte powder coating
CABLE COLOUR: textile cable – black
LED SOURCE: 24V, LED, 5W, 2700K, 273lm, RA80+, DIM

p. 54 | PH1325

PC937 (CGC516, CGSU881, CGCI685, CGSUI905, CCS1948, CCSC619, CECL519, LEDS1945)

GLASS COLOUR: smoke grey – transparent glass
GLASS SURFACE: acid-etched both side surface
INNER GLASS COLOUR: smoke grey – transparent glass
INNER GLASS FINISH: acid-etched both side surface
BODY FINISH: black anodized
CANOPY FINISH: metal – black matte powder coating
CABLE COLOUR: textile cable – black
LED SOURCE: 24V, LED, 5W, 2700K, 273lm, RA80+, DIM

PC937 (CGC554, CGSU881, CGCI683, CGSUI905, CCS1948, CCSC619, CECL519, LEDS1945)

GLASS COLOUR: violet – transparent glass
GLASS SURFACE: acid-etched both side surface
INNER GLASS COLOUR: violet – transparent glass
INNER GLASS FINISH: acid-etched both side surface
BODY FINISH: black anodized
CANOPY FINISH: metal – black matte powder coating
CABLE COLOUR: textile cable – black
LED SOURCE: 24V, LED, 5W, 2700K, 273lm, RA80+, DIM

p. 55 | PH1234

PC943 (CCSC618)

CANOPY FINISH: metal – white matte powder coating

3× PC937 (CGC38, CGSU66, CGCI749, CGSUI905, CCS1917, CECL1918, LEDS1945)

GLASS COLOUR: opaline – transparent glass
GLASS SURFACE: glossy surface
INNER GLASS COLOUR: opaline – transparent glass
INNER GLASS FINISH: acid-etched both side surface
BODY FINISH: silver anodized
CABLE COLOUR: textile cable – light grey
LED SOURCE: 24V, LED, 5W, 2700K, 273lm, RA80+, DIM

p. 56—57 | PH6679

3× PC937 (CGC38, CGSU66, CGCI682, CGSUI905, CCS1917, CCSC618, CECL1918, LEDS1945)

GLASS COLOUR: opaline – transparent glass
GLASS SURFACE: glossy surface
INNER GLASS COLOUR: transparent glass
INNER GLASS FINISH: acid-etched both side surface
BODY FINISH: silver anodized

CANOPY FINISH: metal – white matte powder coating
LED SOURCE: 24V, LED, 5W, 2700K, 273lm, RA80+, DIM

2× PC937 (CGC38, CGSU66, CGCI749, CGSUI906, CCS1917, CCSC618, CECL1918, LEDS1945)

GLASS COLOUR: opaline – transparent glass
GLASS SURFACE: glossy surface
INNER GLASS COLOUR: opaline – transparent glass
INNER GLASS FINISH: glossy surface
BODY FINISH: silver anodized
CANOPY FINISH: metal – white matte powder coating
CABLE COLOUR: textile cable – light grey
LED SOURCE: 24V, LED, 5W, 2700K, 273lm, RA80+, DIM

p. 58 | PH1241

PC943 (CCSC619)

CANOPY FINISH: metal – black matte powder coating

PC937 (CGC23, CGSU66, CGCI683, CGSUI905, CECL519, LEDS1945)

GLASS COLOUR: transparent glass
GLASS SURFACE: glossy surface
INNER GLASS COLOUR: violet – transparent glass
INNER GLASS FINISH: acid-etched both side surface
BODY FINISH: black anodized
CABLE COLOUR: textile cable – black
LED SOURCE: 24V, LED, 5W, 2700K, 273lm, RA80+, DIM

PC937 (CGC23, CGSU66, CGCI685, CGSUI905, CCS1948, CECL519, LEDS1945)

GLASS COLOUR: transparent glass
GLASS SURFACE: glossy surface
INNER GLASS COLOUR: smoke grey – transparent glass
INNER GLASS FINISH: acid-etched both side surface
BODY FINISH: black anodized
CABLE COLOUR: textile cable – black
LED SOURCE: 24V, LED, 5W, 2700K, 273lm, RA80+, DIM

PC937 (CGC23, CGSU66, CGCI749, CGSUI905, CCS1948, CECL519, LEDS1945)

GLASS COLOUR: transparent glass
GLASS SURFACE: glossy surface
INNER GLASS COLOUR: opaline – transparent glass
INNER GLASS FINISH: acid-etched both side surface
BODY FINISH: black anodized
CABLE COLOUR: textile cable – black
LED SOURCE: 24V, LED, 5W, 2700K, 273lm, RA80+, DIM

p. 59 | PH1231

PC937 (CGC23, CGSU66, CGCI685, CGSUI905, CCS1948, CCSC619, CECL519, LEDS1945)

GLASS COLOUR: transparent glass
GLASS SURFACE: glossy surface
INNER GLASS COLOUR: smoke grey – transparent glass
INNER GLASS FINISH: acid-etched both side surface
BODY FINISH: black anodized

CANOPY FINISH: metal – black matte powder coating
CABLE COLOUR: textile cable – black
LED SOURCE: 24V, LED, 5W, 2700K, 273lm, RA80+, DIM

2× PC937 (CGC23, CGSU66, CGCI683, CGSUI905, CCS1948, CCSC619, CECL519, LEDS1945)

GLASS COLOUR: transparent glass
GLASS SURFACE: glossy surface
INNER GLASS COLOUR: violet – transparent glass
INNER GLASS FINISH: acid-etched both side surface
BODY FINISH: black anodized
CANOPY FINISH: metal – black matte powder coating
CABLE COLOUR: textile cable – black
LED SOURCE: 24V, LED, 5W, 2700K, 273lm, RA80+, DIM

PC937 (CGC23, CGSU66, CGCI749, CGSUI906, CCS1948, CCSC619, CECL519, LEDS1945)

GLASS COLOUR: transparent glass
GLASS SURFACE: glossy surface
INNER GLASS COLOUR: opaline – transparent glass
INNER GLASS FINISH: glossy surface
BODY FINISH: black anodized
CANOPY FINISH: metal – black matte powder coating
CABLE COLOUR: textile cable – black
LED SOURCE: 24V, LED, 5W, 2700K, 273lm, RA80+, DIM

p. 60—61 | PH1220

PC943 (CCSC619)

CANOPY FINISH: metal – black matte powder coating

PC937 (CGC23, CGSU66, CGCI912, CGSUI906, CCS1948, CECL519, LEDS1945)

GLASS COLOUR: transparent glass
GLASS SURFACE: glossy surface
INNER GLASS COLOUR: light blue – transparent glass
INNER GLASS FINISH: glossy surface
BODY FINISH: black anodized
CABLE COLOUR: textile cable – black
LED SOURCE: 24V, LED, 5W, 2700K, 273lm, RA80+, DIM

PC937 (CGC23, CGSU66, CGCI912, CGSUI905, CCS1948, CECL519, LEDS1945)

GLASS COLOUR: transparent glass
GLASS SURFACE: glossy surface
INNER GLASS COLOUR: light blue – transparent glass
INNER GLASS FINISH: acid-etched both side surface
BODY FINISH: black anodized
CABLE COLOUR: textile cable – black
LED SOURCE: 24V, LED, 5W, 2700K, 273lm, RA80+, DIM

PC937 (CGC23, CGSU66, CGCI749, CGSUI906, CCS1948, CECL519, LEDS1945)

GLASS COLOUR: transparent glass
GLASS SURFACE: glossy surface
INNER GLASS COLOUR: opaline – transparent glass
INNER GLASS FINISH: glossy surface
BODY FINISH: black anodized
CABLE COLOUR: textile cable – black
LED SOURCE: 24V, LED, 5W, 2700K, 273lm, RA80+, DIM

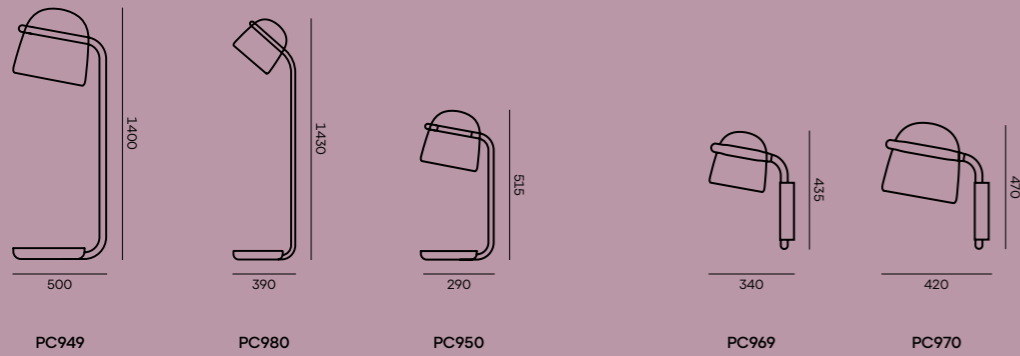

PC949 PC980 PC950 PC969 PC970

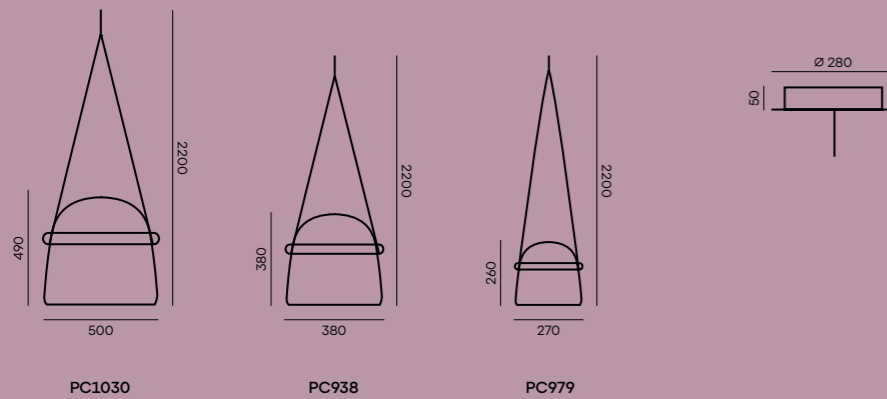

PC1030 PC938 PC979

p. 63 | PH903
PC938 (CGC38, CGSU66, CCS845, CCSC618, GINT788, LEDS1992)
 GLASS COLOUR: opaline – transparent glass
 GLASS SURFACE: glossy surface
 BODY FINISH: metal – white matte powder coating
 CANOPY FINISH: metal – white matte powder coating
 STRAPS: leather straps – natural
 LED SOURCE: 24V, LED, 8W, 2700K, 470lm, RA80+, DIM

p. 64 | PH6676
2*PC938 (CGC23, CGSU66, CCS1948, CCSC619, GINT758, LEDS1992)
 GLASS COLOUR: transparent glass
 GLASS SURFACE: glossy surface
 BODY FINISH: black anodized
 CANOPY FINISH: metal – black matte powder coating
 STRAPS: leather straps – grey
 LED SOURCE: 24V, LED, 8W, 2700K, 470lm, RA80+, DIM

p. 65 | PH6863
PC938 (CGC516, CGSU66, CCS1948, CCSC619, GINT758, LEDS1992)
 GLASS COLOUR: smoke grey – transparent glass
 GLASS SURFACE: glossy surface
 BODY FINISH: black anodized
 CANOPY FINISH: metal – black matte powder coating
 STRAPS: leather straps – grey
 LED SOURCE: 24V, LED, 8W, 2700K, 470lm, RA80+, DIM
PC938 (CGC602, CGSU66, CCS1948, CCSC619, GINT792, LEDS1992)
 GLASS COLOUR: black – transparent glass
 GLASS SURFACE: glossy surface
 BODY FINISH: black anodized
 CANOPY FINISH: metal – black matte powder coating
 STRAPS: leather straps – black
 LED SOURCE: 24V, LED, 8W, 2700K, 470lm, RA80+, DIM

p. 66 | PH927
PC1030 (CGC602, CGSU66, CCS1948, CCSC619, GINT792, LEDS1922)
 GLASS COLOUR: black – transparent glass
 GLASS SURFACE: glossy surface
 BODY FINISH: black anodized
 CANOPY FINISH: metal – black matte powder coating
 STRAPS: leather straps – black
 LED SOURCE: 24V, LED, 12.5W, 2700K, 740lm, DIM

p. 67 | PH6865
PC1030 (CGC516, CGSU66, CCS1948, CCSC619, GINT788, LEDS1922)
 GLASS COLOUR: smoke grey – transparent glass
 GLASS SURFACE: glossy surface
 BODY FINISH: black anodized
 CANOPY FINISH: metal – black matte powder coating
 STRAPS: leather straps – natural
 LED SOURCE: 24V, LED, 12.5W, 2700K, 740lm, DIM
PC979 (CGC516, CGSU66, CCS1948, CCSC619, GINT788, LEDS1989)
 GLASS COLOUR: smoke grey – transparent glass
 GLASS SURFACE: glossy surface
 BODY FINISH: black anodized
 CANOPY FINISH: metal – black matte powder coating
 STRAPS: leather straps – natural
 LED SOURCE: 24V, LED, 4.5W, 2700K, 266lm, RA80+, DIM

p. 68—69 | PH6675
2*PC938 (CGC23, CGSU66, CCS1948, CCSC619, GINT758, LEDS1992)
 GLASS COLOUR: transparent glass
 GLASS SURFACE: glossy surface
 BODY FINISH: black anodized
 CANOPY FINISH: metal – black matte powder coating
 STRAPS: leather straps – grey
 LED SOURCE: 24V, LED, 8W, 2700K, 470lm, RA80+, DIM

p. 70 | PH921
PC950 (CGC38, CGSU66, CCS732, CECL521, LEDS1986)
 GLASS COLOUR: opaline – transparent glass
 GLASS SURFACE: glossy surface
 BODY FINISH: lamp body – white
 CABLE COLOUR: textile cable – white
 LED SOURCE: 24V, LED, 2.5W, 2700K, 141lm, RA80+, DIM
PC950 (CGC554, CGSU66, CCS727, CECL519, LEDS1986)
 GLASS COLOUR: violet – transparent glass
 GLASS SURFACE: glossy surface
 BODY FINISH: lamp body – black
 CABLE COLOUR: textile cable – black
 LED SOURCE: 24V, LED, 2.5W, 2700K, 141lm, RA80+, DIM
PC950 (CGC602, CGSU66, CCS727, CECL519, LEDS1986)
 GLASS COLOUR: black – transparent glass
 GLASS SURFACE: glossy surface
 BODY FINISH: lamp body – black
 CABLE COLOUR: textile cable – black
 LED SOURCE: 24V, LED, 2.5W, 2700K, 141lm, RA80+, DIM

p. 71 | PH913
PC969 (CGC38, CGSU66, CCS732, LEDS1986)
 GLASS COLOUR: opaline – transparent glass
 GLASS SURFACE: glossy surface
 BODY FINISH: lamp body – white
 LED SOURCE: 24V, LED, 2.5W, 2700K, 141lm, RA80+, DIM

p. 72 | PH1356
PC980 (CGC602, CGSU66, CCS727, CECL519, LEDS1989)
 GLASS COLOUR: black – transparent glass
 GLASS SURFACE: glossy surface
 BODY FINISH: lamp body – black
 CABLE COLOUR: textile cable – black
 LED SOURCE: 24V, LED, 4.5W, 2700K, 266lm, RA80+, DIM

p. 73 | PH926
PC979 (CGC602, CGSU66, CCS1948, CCSC619, GINT792, LEDS1989)
 GLASS COLOUR: black – transparent glass
 GLASS SURFACE: glossy surface
 BODY FINISH: black anodized
 CANOPY FINISH: metal – black matte powder coating
 STRAPS: leather straps – black
 LED SOURCE: 24V, LED, 4.5W, 2700K, 266lm, RA80+, DIM
PC1030 (CGC602, CGSU66, CCS1948, CCSC619, GINT792, LEDS1922)
 GLASS COLOUR: black – transparent glass
 GLASS SURFACE: glossy surface
 BODY FINISH: black anodized
 CANOPY FINISH: metal – black matte powder coating
 STRAPS: leather straps – black
 LED SOURCE: 24V, LED, 12.5W, 2700K, 740lm, DIM
PC938 (CGC602, CGSU66, CCS1948, CCSC619, GINT792, LEDS1992)
 GLASS COLOUR: black – transparent glass
 GLASS SURFACE: glossy surface
 BODY FINISH: black anodized
 CANOPY FINISH: metal – black matte powder coating
 STRAPS: leather straps – black
 LED SOURCE: 24V, LED, 8W, 2700K, 470lm, RA80+, DIM

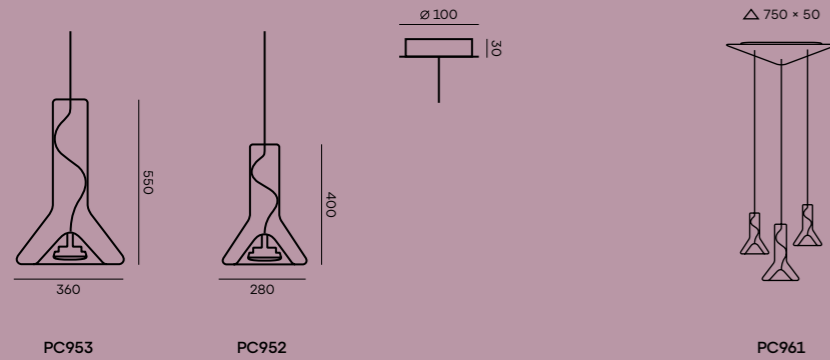

p. 75 | PH4332
PC961 (CCSC619)
 CANOPY FINISH:
 metal – black matte powder coating
2×PC952—PC953 (CGC23, CGSU66, CCS584, CECL519, CEB717)
 GLASS COLOUR: transparent glass
 GLASS SURFACE: glossy surface
 BODY FINISH: copper
 CABLE COLOUR: textile cable – black
 RECOMMENDED BULBS: 230V, GX53, 10W, 2700K, 700lm, RA90, 100°, DIM

p. 76 | PH6867
2×PC952—PC953 (CGC538, CGSU66, CCS69, CCSC897, CECL519, CEB717)
 GLASS COLOUR: smoke brown – transparent glass
 GLASS SURFACE: glossy surface
 BODY FINISH: brass
 CANOPY FINISH: brass
 CABLE COLOUR: textile cable – black
 RECOMMENDED BULBS: 230V, GX53, 10W, 2700K, 700lm, RA90, 100°, DIM

p. 77 | PH5356
PC953 (CGC538, CGSU66, CCS69, CCSC897, CECL519, CEB717)
 GLASS COLOUR: smoke brown – transparent glass
 GLASS SURFACE: glossy surface
 BODY FINISH: brass
 CANOPY FINISH: brass
 CABLE COLOUR: textile cable – black
 RECOMMENDED BULBS: 230V, GX53, 10W, 2700K, 700lm, RA90, 100°, DIM

p. 78—79 | PH6677
2×PC952 (CGC23, CGSU66, CCS584, CCSC896, CECL519, CEB717)
 GLASS COLOUR: transparent glass
 GLASS SURFACE: glossy surface
 BODY FINISH: copper
 CANOPY FINISH: copper
 CABLE COLOUR: textile cable – black
 RECOMMENDED BULBS: 230V, GX53, 10W, 2700K, 700lm, RA90, 100°, DIM

p. 80—81 | PH1372
PC961 (CCSC618)
 CANOPY FINISH: metal – white matte powder coating
PC953—2×PC952 (CGC38, CGSU66, CCS584, CECL521, CEB717)
 GLASS COLOUR: opaline – transparent glass
 GLASS SURFACE: glossy surface
 BODY FINISH: copper
 CABLE COLOUR: textile cable – white
 RECOMMENDED BULBS: 230V, GX53, 10W, 2700K, 700lm, RA90, 100°, DIM

p. 82 | PH1078
PC961 (CCSC619)
 CANOPY FINISH: metal – black matte powder coating
2×PC952—PC953 (CGC23, CGSU66, CCS275, CECL519, CEB717)
 GLASS COLOUR: transparent glass
 GLASS SURFACE: glossy surface
 BODY FINISH: chrome
 CABLE COLOUR: textile cable – black
 RECOMMENDED BULBS: 230V, GX53, 10W, 2700K, 700lm, RA90, 100°, DIM

p. 83 | PH1083
3×PC953 (CGC23, CGSU66, CCS575, CCSC618, CECL521, CEB717)
 GLASS COLOUR: transparent glass
 GLASS SURFACE: glossy surface
 BODY FINISH: white
 CANOPY FINISH: metal – white matte powder coating
 CABLE COLOUR: textile cable – white
 RECOMMENDED BULBS: 230V, GX53, 10W, 2700K, 700lm, RA90, 100°, DIM

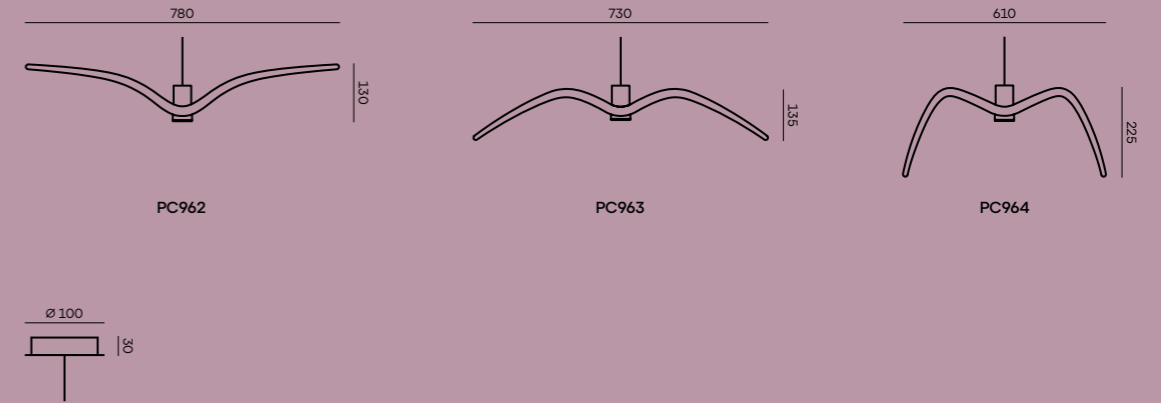

p. 84—85 | PH997
2×PC963—2×PC964—PC962 (CGC772, CCS775, CCSC843, CECL149, CEB825)
 GLASS COLOUR: opal – opaque glass – massif
 BODY FINISH: aluminium
 CANOPY FINISH: aluminium
 CABLE COLOUR: transparent cable
 RECOMMENDED BULBS: 230V, GU10, 5W, 2700K, 336lm, RA90, 100°, DIM

p. 86 | PH990
2×PC962—2×PC963—PC964 (CGC882, CCS775, CCSC843, CECL149, CEB825)
 GLASS COLOUR: smoke grey – massif
 BODY FINISH: aluminium
 CANOPY FINISH: aluminium
 CABLE COLOUR: transparent cable
 RECOMMENDED BULBS: 230V, GU10, 5W, 2700K, 336lm, RA90, 100°, DIM

p. 87 | PH1362
PC962—PC963—PC964 (CGC772, CCS775, CCSC843, CECL149, CEB825)
 GLASS COLOUR: opal – opaque glass – massif
 BODY FINISH: aluminium
 CANOPY FINISH: aluminium
 CABLE COLOUR: transparent cable
 RECOMMENDED BULBS: 230V, GU10, 5W, 2700K, 336lm, RA90, 100°, DIM

p. 88—89 | PH8099
2×PC962—2×PC963—PC964 (CGC1480, CCS1948, CCSC2844, CECL519, CEB825)
 GLASS COLOUR: smoke grey
 BROKISGLASS matte
 BODY FINISH: black anodized
 CANOPY FINISH: black anodized
 CABLE COLOUR: textile cable – black
 RECOMMENDED BULBS: 230V, GU10, 5W, 2700K, 336lm, RA90, 100°, DIM

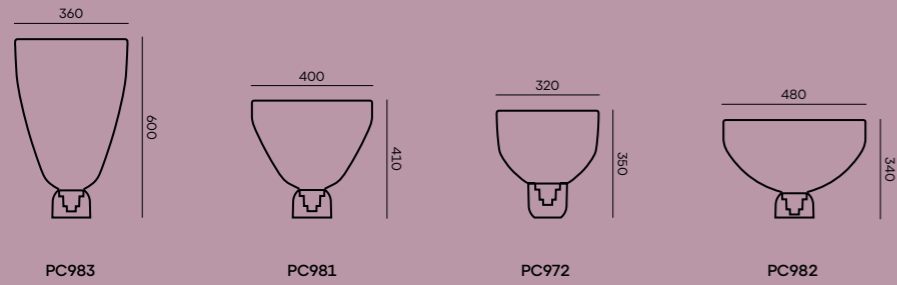

PC983

PC981

PC972

PC982

p. 91 | PH1558

PC981 (CGC554, CGSU806, CGGB813, CGSUB891, CECL1918, CEB825)

GLASS COLOUR: violet – transparent glass
 GLASS SURFACE: glossy – sandblasted (top part)
 BOTTOM GLASS COLOUR: dark smoke grey – transparent glass
 BOTTOM GLASS FINISH: acid-etched
 both side surface
 CABLE COLOUR: textile cable – light grey
 RECOMMENDED BULBS: 230V, GU10, 5W, 2700K, 336lm, RA90, 100°, DIM

p. 92 | PH6694

PC972 (CGC516, CGSU806, CGGB813, CGSUB890, CECL1918, CEB825)

GLASS COLOUR: smoke grey – transparent glass
 GLASS SURFACE: glossy – sandblasted (top part)
 BOTTOM GLASS COLOUR: dark smoke grey – transparent glass
 BOTTOM GLASS FINISH: glossy surface
 CABLE COLOUR: textile cable – light grey
 RECOMMENDED BULBS: 230V, GU10, 5W, 2700K, 336lm, RA90, 100°, DIM

p. 93 | PH850

PC981 (CGC554, CGSU806, CGGB812, CGSUB890, CECL1918, CEB825)

GLASS COLOUR: violet – transparent glass
 GLASS SURFACE: glossy – sandblasted (top part)
 BOTTOM GLASS COLOUR: transparent glass
 BOTTOM GLASS FINISH: glossy surface
 CABLE COLOUR: textile cable – light grey
 RECOMMENDED BULBS: 230V, GU10, 5W, 2700K, 336lm, RA90, 100°, DIM

PC982 (CGC23, CGSU806, CGGB812, CGSUB891, CECL1918, CEB825)

GLASS COLOUR: transparent glass
 GLASS SURFACE: glossy – sandblasted (top part)
 BOTTOM GLASS COLOUR: transparent glass
 BOTTOM GLASS FINISH: acid-etched
 both side surface
 CABLE COLOUR: textile cable – light grey
 RECOMMENDED BULBS: 230V, GU10, 5W, 2700K, 336lm, RA90, 100°, DIM

PC983 (CGC516, CGSU806, CGGB812, CGSUB890, CECL1918, CEB825)

GLASS COLOUR: smoke grey – transparent glass
 GLASS SURFACE: glossy – sandblasted (top part)
 BOTTOM GLASS COLOUR: transparent glass
 BOTTOM GLASS FINISH: glossy surface
 CABLE COLOUR: textile cable – light grey
 RECOMMENDED BULBS: 230V, GU10, 5W, 2700K, 336lm, RA90, 100°, DIM

PC972 (CGC515, CGSU806, CGGB812, CGSUB891, CECL1918, CEB825)

GLASS COLOUR: amber – transparent glass
 GLASS SURFACE: glossy – sandblasted (top part)
 BOTTOM GLASS COLOUR: transparent glass
 BOTTOM GLASS FINISH: acid-etched
 both side surface
 CABLE COLOUR: textile cable – light grey
 RECOMMENDED BULBS: 230V, GU10, 5W, 2700K, 336lm, RA90, 100°, DIM

p. 94 | PH855

PC972 (CGC38, CGSU806, CGGB812, CGSUB890, CECL520, CEB825)

GLASS COLOUR: opaline – transparent glass
 GLASS SURFACE: glossy – sandblasted (top part)
 BOTTOM GLASS COLOUR: transparent glass
 BOTTOM GLASS FINISH: glossy surface
 CABLE COLOUR: textile cable – dark grey
 RECOMMENDED BULBS: 230V, GU10, 5W, 2700K, 336lm, RA90, 100°, DIM

p. 95 | PH859

PC972 (CGC544, CGSU806, CGGB812, CGSUB891, CECL519, CEB825)

GLASS COLOUR: light blue – transparent glass
 GLASS SURFACE: glossy – sandblasted (top part)
 BOTTOM GLASS COLOUR: transparent glass
 BOTTOM GLASS FINISH: acid-etched
 both side surface
 CABLE COLOUR: textile cable – black
 RECOMMENDED BULBS: 230V, GU10, 5W, 2700K, 336lm, RA90, 100°, DIM

p. 96—97 | PH1556

PC982 (CGC23, CGSU806, CGGB812, CGSUB890, CECL521, CEB825)

GLASS COLOUR: transparent glass
 GLASS SURFACE: glossy – sandblasted (top part)
 BOTTOM GLASS COLOUR: transparent glass
 BOTTOM GLASS FINISH: glossy surface
 CABLE COLOUR: textile cable – white
 RECOMMENDED BULBS: 230V, GU10, 5W, 2700K, 336lm, RA90, 100°, DIM

PC981 (CGC554, CGSU806, CGGB812, CGSUB890, CECL521, CEB825)

GLASS COLOUR: violet – transparent glass
 GLASS SURFACE: glossy – sandblasted (top part)
 BOTTOM GLASS COLOUR: transparent glass
 BOTTOM GLASS FINISH: glossy surface
 CABLE COLOUR: textile cable – white
 RECOMMENDED BULBS: 230V, GU10, 5W, 2700K, 336lm, RA90, 100°, DIM

PC983 (CGC516, CGSU806, CGGB812, CGSUB890, CECL521, CEB825)

GLASS COLOUR: smoke grey – transparent glass
 GLASS SURFACE: glossy – sandblasted (top part)
 BOTTOM GLASS COLOUR: transparent glass
 BOTTOM GLASS FINISH: glossy surface
 CABLE COLOUR: textile cable – white
 RECOMMENDED BULBS: 230V, GU10, 5W, 2700K, 336lm, RA90, 100°, DIM

PC972 (CGC515, CGSU806, CGGB812, CGSUB890, CECL521, CEB825)

GLASS COLOUR: amber – transparent glass
 GLASS SURFACE: glossy – sandblasted (top part)
 BOTTOM GLASS COLOUR: transparent glass
 BOTTOM GLASS FINISH: glossy surface
 CABLE COLOUR: textile cable – white
 RECOMMENDED BULBS: 230V, GU10, 5W, 2700K, 336lm, RA90, 100°, DIM

p. 98 | PH1344

PC983 (CGC23, CGSU806, CGGB812, CGSUB891, CECL521, CEB825)

GLASS COLOUR: transparent glass
 GLASS SURFACE: glossy – sandblasted (top part)
 BOTTOM GLASS COLOUR: transparent glass
 BOTTOM GLASS FINISH: acid-etched
 both side surface
 CABLE COLOUR: textile cable – white
 RECOMMENDED BULBS: 230V, GU10, 5W, 2700K, 336lm, RA90, 100°, DIM

p. 99 | PH6834

PC972 (CGC157, CGSU806, CGGB812, CGSUB891, CECL521, CEB825)

GLASS COLOUR: orange – transparent glass
 GLASS SURFACE: glossy – sandblasted (top part)
 BOTTOM GLASS COLOUR: transparent glass
 BOTTOM GLASS FINISH: acid-etched
 both side surface
 CABLE COLOUR: textile cable – white
 RECOMMENDED BULBS: 230V, GU10, 5W, 2700K, 336lm, RA90, 100°, DIM

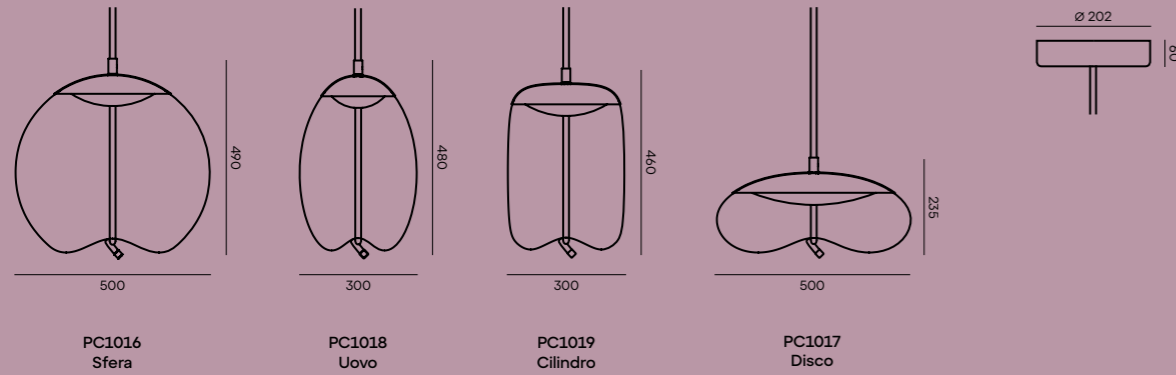

p. 101 | PH1338
PC1037 (CGC538, CGSU880, CCS69, CCSC897, CRP970, LEDS1910)
 GLASS COLOUR: smoke brown – transparent glass
 GLASS SURFACE: matte inner glass finish
 BODY FINISH: brass
 CANOPY FINISH: brass
 ROPE: natural
 LED SOURCE: 24V, LED, 10W, 2700K, 1510lm, RA80+, DIM

CANOPY FINISH: black chrome lacquer
 ROPE: natural
 LED SOURCE: 24V, LED, 10W, 2700K, 1510lm, RA80+, DIM
PC1036 (CGC516, CGSU66, CCS959, CCSC975, CRP970, LEDS1909)
 GLASS COLOUR: smoke grey – transparent glass
 GLASS SURFACE: glossy surface
 BODY FINISH: black chrome lacquer
 CANOPY FINISH: black chrome lacquer
 ROPE: natural
 LED SOURCE: 24V, LED, 7W, 2700K, 895lm, RA80+, DIM
PC1017 (CGC516, CGSU66, CCS959, CCSC975, CRP970, LEDS982)
 GLASS COLOUR: smoke grey – transparent glass
 GLASS SURFACE: glossy surface
 BODY FINISH: black chrome lacquer
 CANOPY FINISH: black chrome lacquer
 ROPE: natural
 LED SOURCE: 24V, LED, 14W, 2700K, 1660lm, RA80+, DIM

LED SOURCE: 24V, LED, 10W, 2700K, 1510lm, RA80+, DIM
PC1017 (CGC538, CGSU66, CCS959, CCSC975, CRP970, LEDS982)
 GLASS COLOUR: smoke brown – transparent glass
 GLASS SURFACE: glossy surface
 BODY FINISH: black chrome lacquer
 CANOPY FINISH: black chrome lacquer
 ROPE: natural
 LED SOURCE: 24V, LED, 14W, 2700K, 1660lm, RA80+, DIM

p. 107 | PH8094
PC1016 (CGC516, CGSU66, CCS2809, CCSC2810, CRP970, LEDS982)
 GLASS COLOUR: smoke grey – transparent glass
 GLASS SURFACE: glossy surface
 BODY FINISH: metal – white matte powder coating with structure
 CANOPY FINISH: metal – white matte powder coating with structure
 ROPE: rope – natural
 LED SOURCE: 24V, LED, 14W, 2700K, 1660lm, RA80+, DIM

KNOT SMALL

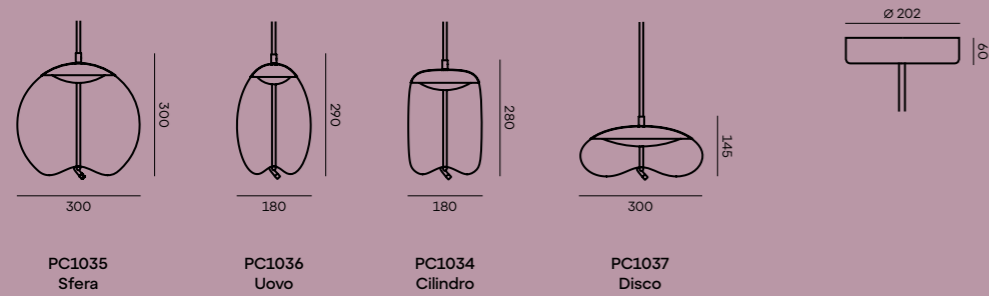

PC1019 (CGC538, CGSU880, CCS69, CCSC897, CRP970, LEDS982)
 GLASS COLOUR: smoke brown – transparent glass
 GLASS SURFACE: matte inner glass finish
 BODY FINISH: brass
 CANOPY FINISH: brass
 ROPE: natural
 LED SOURCE: 24V, LED, 14W, 2700K, 1660lm, RA80+, DIM

p. 104 | PH1341
PC1016 – PC1019 (CGC516, CGSU66, CCS584, CCSC896, CRP970, LEDS982)
 GLASS COLOUR: smoke grey – transparent glass
 GLASS SURFACE: glossy surface
 BODY FINISH: copper
 CANOPY FINISH: copper
 ROPE: natural
 LED SOURCE: 24V, LED, 14W, 2700K, 1660lm, RA80+, DIM

p. 108—109 | PH8092
PC1034 (CGC38, CGSU66, CCS2809, CCSC2810, CRP970, LEDS1910)
 GLASS COLOUR: opaline – transparent glass
 GLASS SURFACE: glossy surface
 BODY FINISH: metal – white matte powder coating with structure
 CANOPY FINISH: metal – white matte powder coating with structure
 ROPE: rope – natural
 LED SOURCE: 24V, LED, 5W, 2700K, 620lm, RA90+, DIM

p. 102—103 | PH1335
PC1037 (CGC516, CGSU66, CCS959, CCSC975, CRP970, LEDS1910)
 GLASS COLOUR: smoke grey – transparent glass
 GLASS SURFACE: glossy surface
 BODY FINISH: black chrome lacquer
 CANOPY FINISH: black chrome lacquer
 ROPE: natural
 LED SOURCE: 24V, LED, 10W, 2700K, 1510lm, RA80+, DIM

p. 105 | PH825
PC1078 (CGC516, CGSU66, CCS69, CRP970, CECL519, LEDS982)
 GLASS COLOUR: smoke grey – transparent glass
 GLASS SURFACE: glossy surface
 BODY FINISH: brass
 ROPE: natural
 CABLE COLOUR: textile cable – black
 LED SOURCE: 24V, LED, 14W, 2700K, 1660lm, RA80+, DIM

PC1036 (CGC38, CGSU66, CCS2809, CCSC2810, CRP970, LEDS1909)
 GLASS COLOUR: opaline – transparent glass
 GLASS SURFACE: glossy surface
 BODY FINISH: metal – white matte powder coating with structure
 CANOPY FINISH: metal – white matte powder coating with structure
 ROPE: rope – natural
 LED SOURCE: 24V, LED, 3.4W, 2700K, 425lm, RA90+, DIM

PC1016 (CGC516, CGSU66, CCS959, CCSC975, CRP970, LEDS982)
 GLASS COLOUR: smoke grey – transparent glass
 GLASS SURFACE: glossy surface
 BODY FINISH: black chrome lacquer
 CANOPY FINISH: black chrome lacquer
 ROPE: natural
 LED SOURCE: 24V, LED, 14W, 2700K, 1660lm, RA80+, DIM

p. 106 | PH1337
PC1036 (CGC538, CGSU66, CCS959, CCSC975, CRP970, LEDS1909)
 GLASS COLOUR: smoke brown – transparent glass
 GLASS SURFACE: glossy surface
 BODY FINISH: black chrome lacquer
 CANOPY FINISH: black chrome lacquer
 ROPE: natural
 LED SOURCE: 24V, LED, 7W, 2700K, 895lm, RA80+, DIM

PC1016 (CGC516, CGSU66, CCS2809, CCSC2810, CRP970, LEDS982)
 GLASS COLOUR: smoke grey – transparent glass
 GLASS SURFACE: glossy surface
 BODY FINISH: metal – white matte powder coating with structure
 CANOPY FINISH: metal – white matte powder coating with structure
 ROPE: rope – natural
 LED SOURCE: 24V, LED, 14W, 2700K, 1660lm, RA80+, DIM

KNOT TABLE

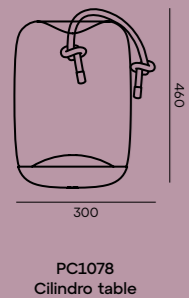

PC1034 (CGC516, CGSU66, CCS959, CCSC975, CRP970, LEDS1910)
 GLASS COLOUR: smoke grey – transparent glass
 GLASS SURFACE: glossy surface
 BODY FINISH: black chrome lacquer
 CANOPY FINISH: black chrome lacquer
 ROPE: natural
 LED SOURCE: 24V, LED, 10W, 2700K, 1510lm, RA80+, DIM

PC1016 (CGC538, CGSU66, CCS959, CCSC975, CRP970, LEDS982)
 GLASS COLOUR: smoke brown – transparent glass
 GLASS SURFACE: glossy surface
 BODY FINISH: black chrome lacquer
 CANOPY FINISH: black chrome lacquer
 ROPE: natural
 LED SOURCE: 24V, LED, 14W, 2700K, 1660lm, RA80+, DIM

PC1035 – PC1037 (CGC38, CGSU66, CCS2809, CCSC2810, CRP970, LEDS1910)
 GLASS COLOUR: opaline – transparent glass
 GLASS SURFACE: glossy surface
 BODY FINISH: metal – white matte powder coating with structure
 CANOPY FINISH: metal – white matte powder coating with structure
 ROPE: rope – natural
 LED SOURCE: 24V, LED, 5W, 2700K, 620lm, RA90+, DIM

PURO SOLO

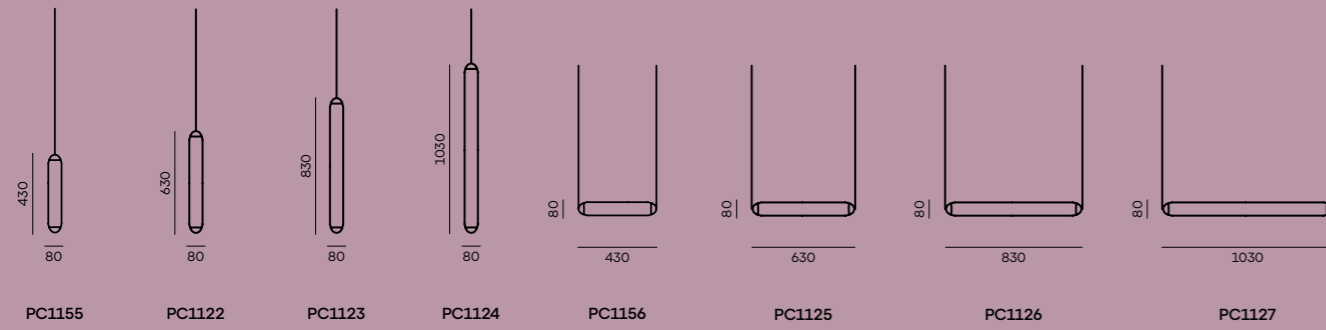

PURO SPARKLE

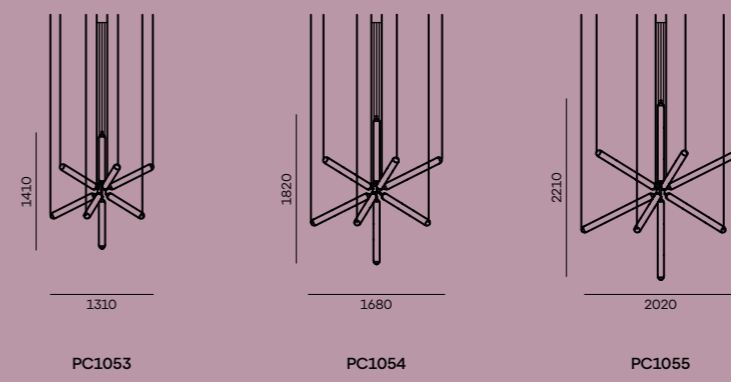

PURO ECLECTIC

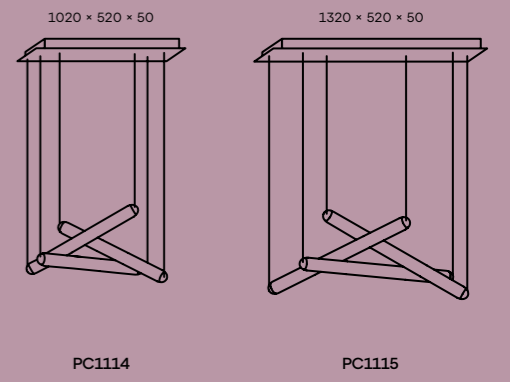

PURO SINGLE

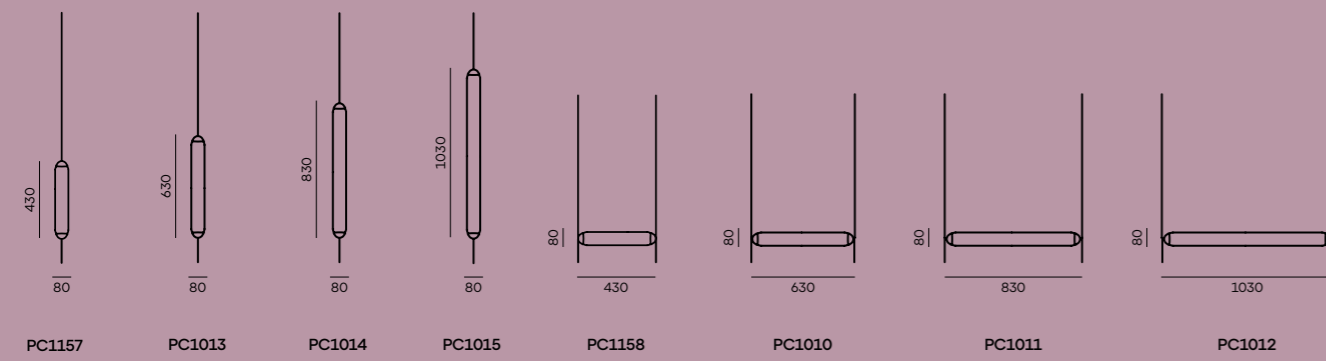

PURO CONTOUR

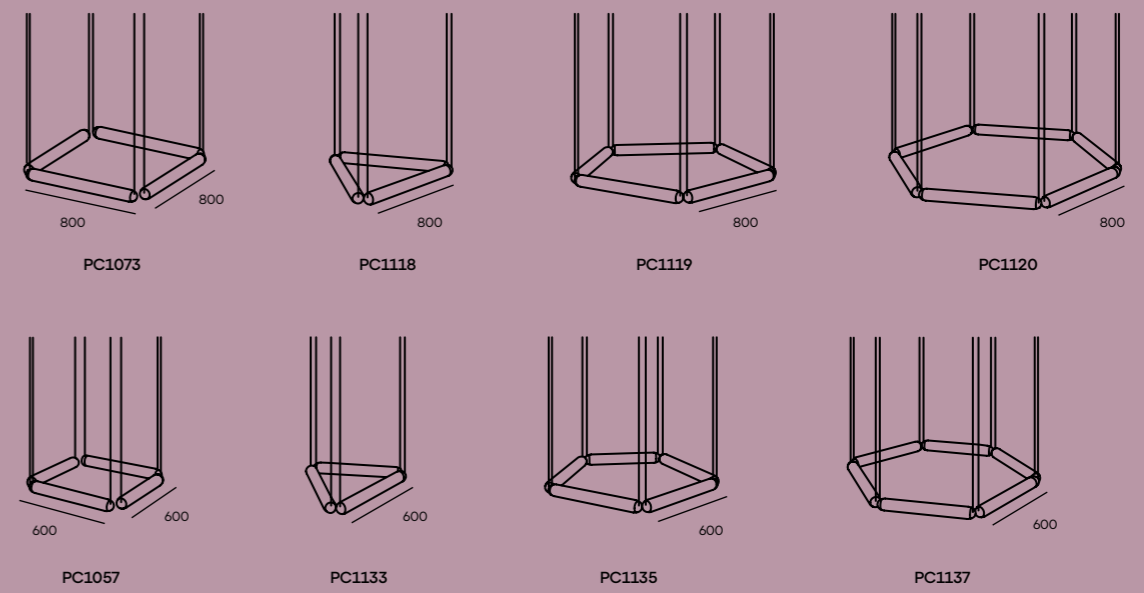

Canopy for Puro Solo and Puro Single

PURO SPOTLIGHT



PC1121

PURO FLOOR

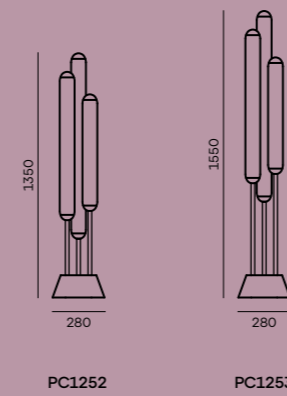

CANOPY FINISH: glass – black
 CABLE COLOUR: textile cable – black
 LED SOURCE: 1000mm 24V, LED, 17.5W, 2700K, 1035lm, RA80+, DIM
PC1121 (CGGB977, CGSUB891, CCS846, CCSC619, CECL519, CEBBP1031)
 BOTTOM GLASS COLOUR: smoke grey – transparent glass
 BOTTOM GLASS FINISH: acid-etched both side surface
 BODY FINISH: metal – black matte powder coating
 CABLE COLOUR: textile cable – black
 LED SOURCE: 24V, LED, 5W, 2700K, 240lm, RA90, DIM

p. 120 — 121 | PH1036
PC1114 (CGC39, CGSU881, CCS845, CCSC618, CECL521, LEDS1929)
 GLASS COLOUR: triplex opal
 GLASS SURFACE: acid-etched both side surface
 BODY FINISH: metal – white matte powder coating
 CANOPY FINISH: metal – white matte powder coating
 CABLE COLOUR: textile cable – white
 LED SOURCE: 800mm 24V, LED, 15W, 2700K, 880lm, RA80+, DIM

p. 122 | PH6512
PC1252 (CGC39, CGSU881, CCS2809, CECL521, LEDS2833)
 GLASS COLOUR: triplex opal
 GLASS SURFACE: acid-etched both side surface
 BODY FINISH: metal – white matte powder coating with structure
 CABLE COLOUR: textile cable – white
 LED SOURCE: 24V, LED, 45W, 2700K, 2400lm, RA80+, DIM

p. 123 | PH1042
 PC1010, 2×PC1121
 PC1014, PC1121
 PC1015, PC1121
 PC1013, PC1121
PC1010 (CGC39, CGSU881, CCS845, CCSC2403, CECL521, LEDS1926)
 GLASS COLOUR: triplex opal
 GLASS SURFACE: acid-etched both side surface
 BODY FINISH: metal – white matte powder coating
 CANOPY FINISH: glass – white
 CABLE COLOUR: textile cable – white
 LED SOURCE: 600mm 24V, LED, 9.5W, 2700K, 547lm, RA80+, DIM
2×PC1121 (CGGB812, CGSUB890, CCS845, CECL521, CEBBP1031)
 BOTTOM GLASS COLOUR: transparent glass
 BOTTOM GLASS FINISH: glossy surface
 BODY FINISH: metal – white matte powder coating
 CABLE COLOUR: textile cable – white
 LED SOURCE: 24V, LED, 5W, 2700K, 240lm, RA90, DIM

PC1014 (CGC39, CGSU881, CCS845, CCSC2403, CECL521, LEDS1929)
 GLASS COLOUR: triplex opal
 GLASS SURFACE: acid-etched both side surface
 BODY FINISH: metal – white matte powder coating
 CANOPY FINISH: glass – white
 CABLE COLOUR: textile cable – white

LED SOURCE: 800mm 24V, LED, 15W, 2700K, 880lm, RA80+, DIM
PC1121 (CGGB812, CGSUB890, CCS845, CECL521, CEBBP1031)
 BOTTOM GLASS COLOUR: transparent glass
 BOTTOM GLASS FINISH: glossy surface
 BODY FINISH: metal – white matte powder coating
 CABLE COLOUR: textile cable – white
 LED SOURCE: 24V, LED, 5W, 2700K, 240lm, RA90, DIM
PC1015 (CGC39, CGSU881, CCS845, CCSC2403, CECL521, LEDS1932)
 GLASS COLOUR: triplex opal
 GLASS SURFACE: acid-etched both side surface
 BODY FINISH: metal – white matte powder coating
 CANOPY FINISH: glass – white
 CABLE COLOUR: textile cable – white
 LED SOURCE: 1000mm 24V, LED, 17.5W, 2700K, 1035lm, RA80+, DIM

PC1121 (CGGB812, CGSUB890, CCS845, CECL521, CEBBP1031)
 BOTTOM GLASS COLOUR: transparent glass
 BOTTOM GLASS FINISH: glossy surface
 BODY FINISH: metal – white matte powder coating
 CABLE COLOUR: textile cable – white
 LED SOURCE: 24V, LED, 5W, 2700K, 240lm, RA90, DIM
PC1013 (CGC39, CGSU881, CCS845, CCSC2403, CECL521, LEDS1926)
 GLASS COLOUR: triplex opal
 GLASS SURFACE: acid-etched both side surface
 BODY FINISH: metal – white matte powder coating
 CANOPY FINISH: glass – white
 CABLE COLOUR: textile cable – white
 LED SOURCE: 600mm 24V, LED, 9.5W, 2700K, 547lm, RA80+, DIM

p. 124 — 125 | PH1023
PC1073 (CGC1507, CGSU881, CCS846, CCSC619, CECL519, LEDS1929)
 GLASS COLOUR: dark grey – opaline
 GLASS SURFACE: acid-etched both side surface
 BODY FINISH: metal – black matte powder coating
 CANOPY FINISH: metal – black matte powder coating
 CABLE COLOUR: textile cable – black
 LED SOURCE: 800mm 24V, LED, 15W, 2700K, 880lm, RA80+, DIM

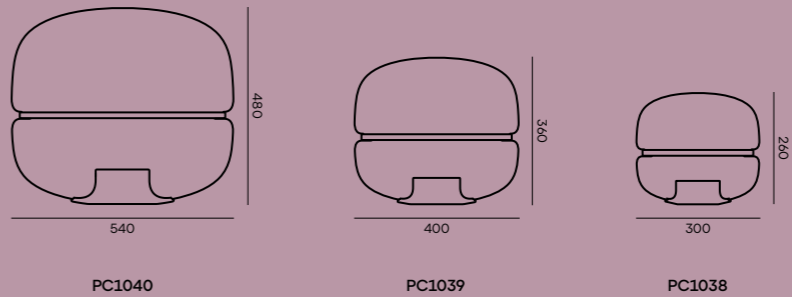

p. 127 | PH1566
PC1040 (CGC46, CGSU66, CSFB1535, CSOP1532, CECL521, CEB717)
 GLASS COLOUR: light pink – transparent glass
 GLASS SURFACE: glossy surface
 BASE FINISH: onyx white
 PLATE FINISH: onyx white
 CABLE COLOUR: textile cable – white
 RECOMMENDED BULBS: 230V, GX53, 10W, 2700K, 700lm, RA90, 100°, DIM

p. 128 | PH870
PC1040 (CGC23, CGSU66, CSFB1535, CSOP1532, CECL521, CEB717)
 GLASS COLOUR: transparent glass
 GLASS SURFACE: glossy surface
 BASE FINISH: onyx white
 PLATE FINISH: onyx white
 CABLE COLOUR: textile cable – white
 RECOMMENDED BULBS: 230V, GX53, 10W, 2700K, 700lm, RA90, 100°, DIM

p. 129 | PH872
PC1039 (CGC516, CGSU66, CSFB1535, CSOP1532, CECL521, CEB717)
 GLASS COLOUR: smoke grey – transparent glass
 GLASS SURFACE: glossy surface
 BASE FINISH: onyx white
 PLATE FINISH: onyx white
 CABLE COLOUR: textile cable – white
 RECOMMENDED BULBS: 230V, GX53, 10W, 2700K, 700lm, RA90, 100°, DIM

p. 130 — 131 | PH881
PC1039 (CGC23, CGSU66, CSFB1576, CSOP1533, CECL1918, CEB717)
 GLASS COLOUR: transparent glass
 GLASS SURFACE: glossy surface
 BASE FINISH: onyx honey
 PLATE FINISH: onyx honey
 CABLE COLOUR: textile cable – light grey
 RECOMMENDED BULBS: 230V, GX53, 10W, 2700K, 700lm, RA90, 100°, DIM

p. 132 — 133 | PH1574
PC1038 (CGC516, CGSU66, CSFB1535, CSOP1532, CECL521, CEB717)
 GLASS COLOUR: smoke grey – transparent glass
 GLASS SURFACE: glossy surface
 BASE FINISH: onyx white
 PLATE FINISH: onyx white
 CABLE COLOUR: textile cable – white
 RECOMMENDED BULBS: 230V, GX53, 10W, 2700K, 700lm, RA90, 100°, DIM
PC1040 (CGC46, CGSU66, CSFB1535, CSOP1532, CECL521, CEB717)
 GLASS COLOUR: light pink – transparent glass
 GLASS SURFACE: glossy surface
 BASE FINISH: onyx white
 PLATE FINISH: onyx white
 CABLE COLOUR: textile cable – white
 RECOMMENDED BULBS: 230V, GX53, 10W, 2700K, 700lm, RA90, 100°, DIM
PC1039 (CGC23, CGSU66, CSFB1535, CSOP1532, CECL521, CEB717)
 GLASS COLOUR: transparent glass
 GLASS SURFACE: glossy surface
 BASE FINISH: onyx white
 PLATE FINISH: onyx white
 CABLE COLOUR: textile cable – white
 RECOMMENDED BULBS: 230V, GX53, 10W, 2700K, 700lm, RA90, 100°, DIM
PC1038 (CGC515, CGSU66, CSFB1576, CSOP1533, CECL521, CEB717)
 GLASS COLOUR: amber – transparent glass
 GLASS SURFACE: glossy surface
 BASE FINISH: onyx honey
 PLATE FINISH: onyx honey
 CABLE COLOUR: textile cable – white
 RECOMMENDED BULBS: 230V, GX53, 10W, 2700K, 700lm, RA90, 100°, DIM

p. 134 | PH880
PC1038 (CGC23, CGSU66, CSFB1574, CSOP1577, CECL520, CEB717)
 GLASS COLOUR: transparent glass
 GLASS SURFACE: glossy surface

BASE FINISH: European oak – stained black
 PLATE FINISH: BROKISGLASS – smoke grey matte
 CABLE COLOUR: textile cable – dark grey
 RECOMMENDED BULBS: 230V, GX53, 10W, 2700K, 700lm, RA90, 100°, DIM

p. 135 | PH862
PC1038 (CGC515, CGSU66, CSFB1535, CSOP1532, CECL521, CEB717)
 GLASS COLOUR: amber – transparent glass
 GLASS SURFACE: glossy surface
 BASE FINISH: onyx white
 PLATE FINISH: onyx white
 CABLE COLOUR: textile cable – white
 RECOMMENDED BULBS: 230V, GX53, 10W, 2700K, 700lm, RA90, 100°, DIM

JACK O' LANTERN SMALL

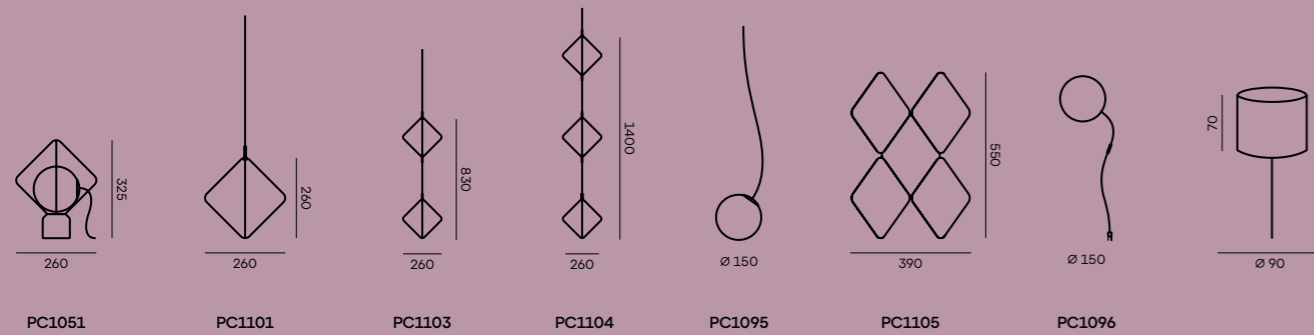

JACK O' LANTERN LARGE

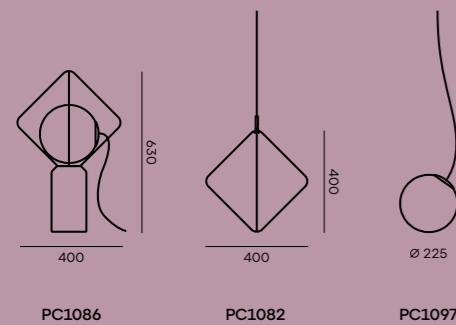

p. 137 | PH3420

PC1051 (CGC39, CGSU881, CSFB2682, CCS2354, CECL519, CEB2773)

GLASS COLOUR: triplex opal
GLASS SURFACE: acid-etched both side surface
BASE FINISH: satinated Rosso Francia marble
BODY FINISH: liquid metal coating – chrome
CABLE COLOUR: textile cable – black
RECOMMENDED BULBS: 230V, G9, 4.5W, 2700K, DIM

p. 138 | PH1330

PC1051 (CGC39, CGSU881, CSFB2361, CCS2355, CECL1918, CEB2773)

GLASS COLOUR: triplex opal
GLASS SURFACE: acid-etched both side surface
BASE FINISH: satinated Carrara marble
BODY FINISH: liquid metal coating – black chrome
CABLE COLOUR: textile cable – light grey
RECOMMENDED BULBS: 230V, G9, 4.5W, 2700K, DIM

PC1086 (CGC39, CGSU881, CSFB2361, CCS2355, CECL1918, CEB1828)

GLASS COLOUR: triplex opal
GLASS SURFACE: acid-etched both side surface
BASE FINISH: satinated Carrara marble
BODY FINISH: liquid metal coating – black chrome
CABLE COLOUR: textile cable – light grey
RECOMMENDED BULBS: 230V, G9, 4.5W, 2700K, DIM

p. 139 | PH1385

PC1051 (CGC39, CGSU881, CSFB2360, CCS2355, CECL519, CEB2773)

GLASS COLOUR: triplex opal
GLASS SURFACE: acid-etched both side surface
BASE FINISH: satinated Nero Marquina marble
BODY FINISH: liquid metal coating – black chrome
CABLE COLOUR: textile cable – black
RECOMMENDED BULBS: 230V, G9, 4.5W, 2700K, DIM

p. 140 | PH1520

PC1051 (CGC516, CGSU881, CSFB2360, CCS2673, CECL519, CEB2773)

GLASS COLOUR: smoke grey – transparent glass
GLASS SURFACE: acid-etched both side surface
BASE FINISH: satinated Nero Marquina marble
BODY FINISH: black matte powder coating with structure
CABLE COLOUR: textile cable – black
RECOMMENDED BULBS: 230V, G9, 4.5W, 2700K, DIM

p. 141 | PH1503

PC1082 + PC1097 (CGC39, CGSU881, CCS2354, CCSC2363, CECL1918, CEB1828)

GLASS COLOUR: triplex opal
GLASS SURFACE: acid-etched both side surface
BODY FINISH: liquid metal coating – chrome
CANOPY FINISH: liquid metal coating – chrome
CABLE COLOUR: textile cable – light grey
RECOMMENDED BULBS: 230V, G9, 4.5W, 2700K, DIM

2*PC1101 + 2*PC1095 (CGC39, CGSU881, CCS2354, CCSC2363, CECL1918, CEB2773)

GLASS COLOUR: triplex opal
GLASS SURFACE: acid-etched both side surface
BODY FINISH: liquid metal coating – chrome
CANOPY FINISH: liquid metal coating – chrome

CABLE COLOUR: textile cable – light grey
RECOMMENDED BULBS: 230V, G9, 4.5W, 2700K, DIM

PC1051 (CGC39, CGSU881, CSFB2360, CCS2355, CECL1918, CEB2773)

GLASS COLOUR: triplex opal
GLASS SURFACE: acid-etched both side surface
BASE FINISH: satinated Nero Marquina marble
BODY FINISH: liquid metal coating – black chrome
CABLE COLOUR: textile cable – light grey
RECOMMENDED BULBS: 230V, G9, 4.5W, 2700K, DIM

PC1086 (CGC39, CGSU881, CSFB2360, CCS2355, CECL519, CEB1828)

GLASS COLOUR: triplex opal
GLASS SURFACE: acid-etched both side surface
BASE FINISH: satinated Nero Marquina marble
BODY FINISH: liquid metal coating – black chrome
CABLE COLOUR: textile cable – black
RECOMMENDED BULBS: 230V, G9, 4.5W, 2700K, DIM

p. 142—143 | PH3397

PC1051 (CGC516, CGSU881, CSFB2361, CCS2354, CECL519, CEB2773)

GLASS COLOUR: smoke grey – transparent glass
GLASS SURFACE: acid-etched both side surface
BASE FINISH: satinated Carrara marble
BODY FINISH: liquid metal coating – chrome
CABLE COLOUR: textile cable – black
RECOMMENDED BULBS: 230V, G9, 4.5W, 2700K, DIM

PC1051 (CGC516, CGSU881, CSFB2360, CCS2353, CECL1918, CEB2773)

GLASS COLOUR: smoke grey – transparent glass
GLASS SURFACE: acid-etched both side surface
BASE FINISH: satinated Nero Marquina marble
BODY FINISH: liquid metal coating – copper
CABLE COLOUR: textile cable – light grey
RECOMMENDED BULBS: 230V, G9, 4.5W, 2700K, DIM

PC1051 (CGC39, CGSU881, CSFB2360, CCS2673, CECL519, CEB2773)

GLASS COLOUR: triplex opal
GLASS SURFACE: acid-etched both side surface
BASE FINISH: satinated Nero Marquina marble
BODY FINISH: black matte powder coating with structure
CABLE COLOUR: textile cable – black
RECOMMENDED BULBS: 230V, G9, 4.5W, 2700K, DIM

PC1051 (CGC46, CGSU881, CSFB2361, CCS2353, CECL521, CEB2773)

GLASS COLOUR: light pink – transparent glass
GLASS SURFACE: acid-etched both side surface
BASE FINISH: satinated Carrara marble
BODY FINISH: liquid metal coating – copper
CABLE COLOUR: textile cable – white
RECOMMENDED BULBS: 230V, G9, 4.5W, 2700K, DIM

PC1051 (CGC516, CGSU881, CSFB2360, CCS2355, CECL519, CEB2773)

GLASS COLOUR: smoke grey – transparent glass
GLASS SURFACE: acid-etched both side surface
BASE FINISH: satinated Nero Marquina marble
BODY FINISH: liquid metal coating – black chrome
CABLE COLOUR: textile cable – black
RECOMMENDED BULBS: 230V, G9, 4.5W, 2700K, DIM

p. 144 | PH1399

PC1101 + PC1095 (CGC39, CGSU881, CCS2354, CCSC2363, CECL1918, CEB2773)

GLASS COLOUR: triplex opal
GLASS SURFACE: acid-etched both side surface
BODY FINISH: liquid metal coating – chrome
CANOPY FINISH: liquid metal coating – chrome
CABLE COLOUR: textile cable – light grey
RECOMMENDED BULBS: 230V, G9, 4.5W, 2700K, DIM

PC1051 (CGC39, CGSU881, CSFB2361, CCS2354, CECL1918, CEB2773)

GLASS COLOUR: triplex opal
GLASS SURFACE: acid-etched both side surface
BASE FINISH: satinated Carrara marble
BODY FINISH: liquid metal coating – chrome
CABLE COLOUR: textile cable – light grey
RECOMMENDED BULBS: 230V, G9, 4.5W, 2700K, DIM

p. 145 | PH1333

PC1105 + PC1096 (CGC45, CGSU881, CCS2353, CECL521, CEB2773)

GLASS COLOUR: light pink – transparent glass
GLASS SURFACE: acid-etched both side surface
BODY FINISH: liquid metal coating – copper
CABLE COLOUR: textile cable – white
RECOMMENDED BULBS: 230V, G9, 4.5W, 2700K, DIM

p. 146 | PH813

PC1105 + PC1096 (CGC45, CGSU881, CCS2354, CECL521, CEB2773)

GLASS COLOUR: light pink – transparent glass
GLASS SURFACE: acid-etched both side surface
BODY FINISH: liquid metal coating – chrome
CABLE COLOUR: textile cable – black
RECOMMENDED BULBS: 230V, G9, 4.5W, 2700K, DIM

p. 147 | PH794

PC1104 + 3*PC1095 (CGC46, CGSU881, CCS2353, CCSC2362, CECL521, CEB2773)

GLASS COLOUR: light pink – transparent glass
GLASS SURFACE: acid-etched both side surface
BODY FINISH: liquid metal coating – copper
CANOPY FINISH: liquid metal coating – copper
CABLE COLOUR: textile cable – white
RECOMMENDED BULBS: 230V, G9, 4.5W, 2700K, DIM

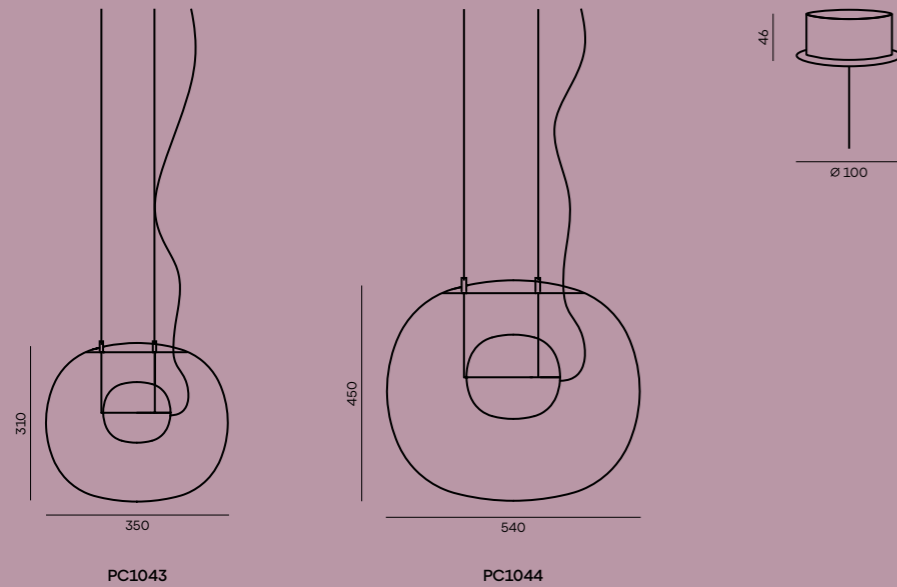

p. 149 | PH6869

PC1044 (CGC516, CGSU66, CGCI685, CGSUI905, CCS68, CCSC974, CECL519, CEB1828)

GLASS COLOUR: smoke grey – transparent glass
 GLASS SURFACE: glossy surface
 INNER GLASS COLOUR: smoke grey – transparent glass
 INNER GLASS FINISH: acid-etched both side surface
 BODY FINISH: brushed stainless steel
 CANOPY FINISH: brushed stainless steel
 CABLE COLOUR: textile cable – black
 RECOMMENDED BULBS: 230V, G9, 4.5W, 2700K, DIM

PC1043 (CGC23, CGSU66, CGCI685, CGSUI905, CCS68, CCSC974, CECL519, CEB1828)

GLASS COLOUR: transparent glass
 GLASS SURFACE: glossy surface
 INNER GLASS COLOUR: smoke grey – transparent glass
 INNER GLASS FINISH: acid-etched both side surface
 BODY FINISH: brushed stainless steel
 CANOPY FINISH: brushed stainless steel
 CABLE COLOUR: textile cable – black
 RECOMMENDED BULBS: 230V, G9, 4.5W, 2700K, DIM

p. 150—151 | PH1171

2×PC1043 (CGC516, CGSU66, CGCI907, GSUI905, CCS68, CCSC974, CECL519, CEB1828)

GLASS COLOUR: smoke grey – transparent glass
 GLASS SURFACE: glossy surface
 INNER GLASS COLOUR: triplex opal
 INNER GLASS FINISH: acid-etched both side surface
 BODY FINISH: brushed stainless steel
 CANOPY FINISH: brushed stainless steel
 CABLE COLOUR: textile cable – black
 RECOMMENDED BULBS: 230V, G9, 4.5W, 2700K, DIM

PC1044 (CGC23, CGSU66, CGCI907, CGSUI905, CCS68, CCSC974, CECL519, CEB1828)

GLASS COLOUR: transparent glass
 GLASS SURFACE: glossy surface
 INNER GLASS COLOUR: triplex opal
 INNER GLASS FINISH: acid-etched both side surface
 BODY FINISH: brushed stainless steel
 CANOPY FINISH: brushed stainless steel
 CABLE COLOUR: textile cable – black
 RECOMMENDED BULBS: 230V, G9, 4.5W, 2700K, DIM

p. 152 | PH1170

2×PC1043—PC1044 (CGC516, CGSU66, CGCI907, CGSUI905, CCS68, CCSC974, CECL519, CEB1828)

GLASS COLOUR: smoke grey – transparent glass
 GLASS SURFACE: glossy surface
 INNER GLASS COLOUR: triplex opal
 INNER GLASS FINISH: acid-etched both side surface
 BODY FINISH: brushed stainless steel
 CANOPY FINISH: brushed stainless steel
 CABLE COLOUR: textile cable – black
 RECOMMENDED BULBS: 230V, G9, 4.5W, 2700K, DIM

PC1044 (CGC23, CGSU66, CGCI913, CGSUI905, CCS68, CCSC974, CECL519, CEB1828)

GLASS COLOUR: transparent glass
 GLASS SURFACE: glossy surface
 INNER GLASS COLOUR: red – transparent glass
 INNER GLASS FINISH: acid-etched both side surface
 BODY FINISH: brushed stainless steel
 CANOPY FINISH: brushed stainless steel
 CABLE COLOUR: textile cable – black
 RECOMMENDED BULBS: 230V, G9, 4.5W, 2700K, DIM

p. 153 | PH703

PC1044 (CGC23, CGSU66, CGCI913, CGSUI905, CCS68, CCSC974, CECL1918, CEB1828)

GLASS COLOUR: transparent glass
 GLASS SURFACE: glossy surface
 INNER GLASS COLOUR: red – transparent glass
 INNER GLASS FINISH: acid-etched both side surface
 BODY FINISH: brushed stainless steel
 CANOPY FINISH: brushed stainless steel
 CABLE COLOUR: textile cable – light grey
 RECOMMENDED BULBS: 230V, G9, 4.5W, 2700K, DIM

p. 154—155 | PH1400

2×PC1044 (CGC23, CGSU66, CGCI907, CGSUI905, CCS68, CCSC974, CECL519, CEB1828)

GLASS COLOUR: transparent glass
 GLASS SURFACE: glossy surface
 INNER GLASS COLOUR: triplex opal
 INNER GLASS FINISH: acid-etched both side surface
 BODY FINISH: brushed stainless steel
 CANOPY FINISH: brushed stainless steel
 CABLE COLOUR: textile cable – black
 RECOMMENDED BULBS: 230V, G9, 4.5W, 2700K, DIM

IVY VERTICAL

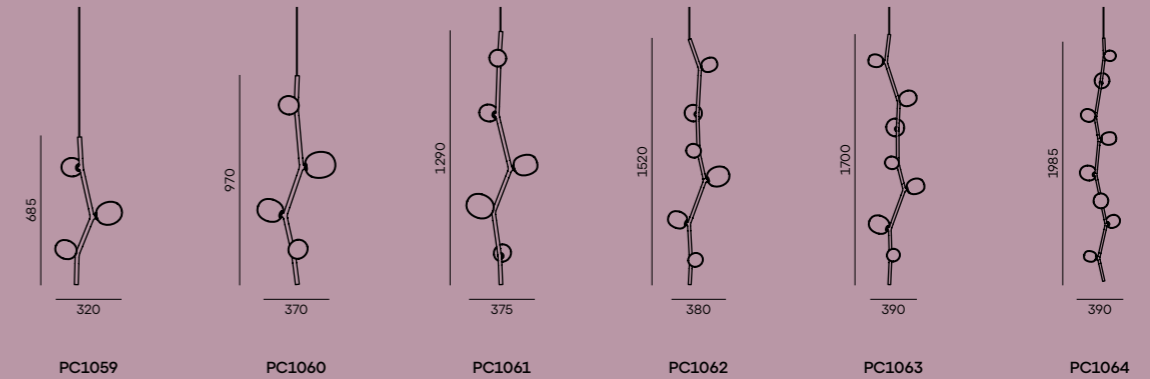

IVY HORIZONTAL

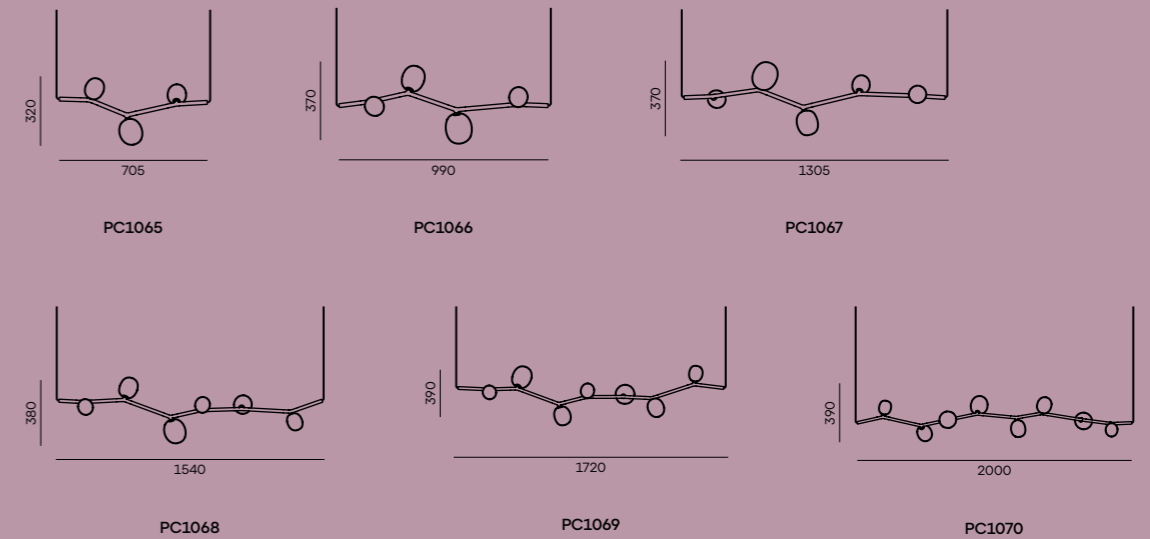

Canopy for Ivy Vertical and Ivy Horizontal

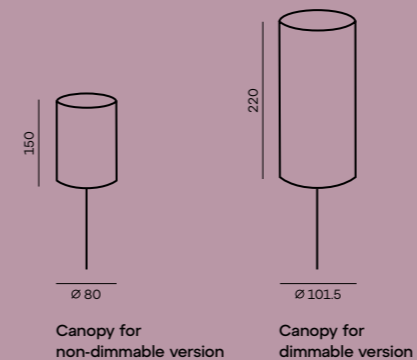

IVY FLOOR

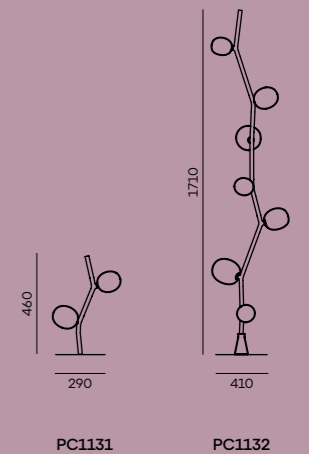

IVY CEILING

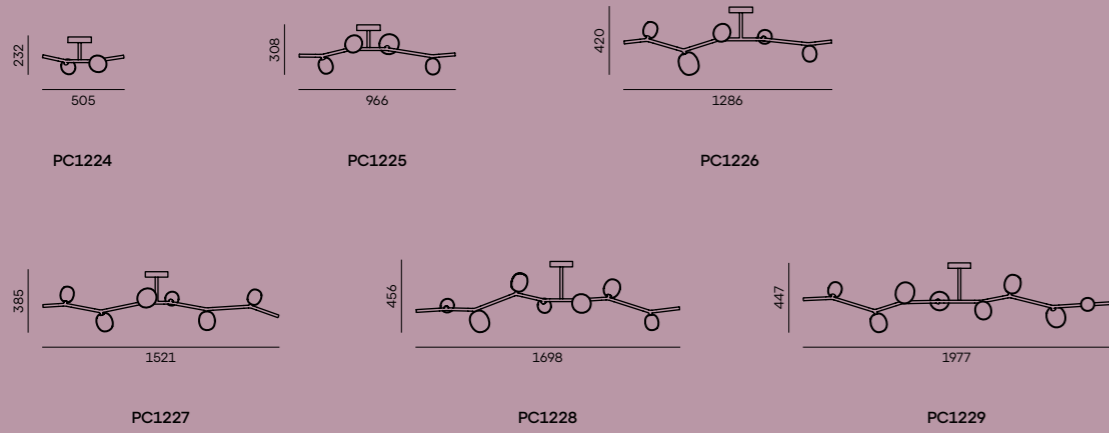

IVY WALL

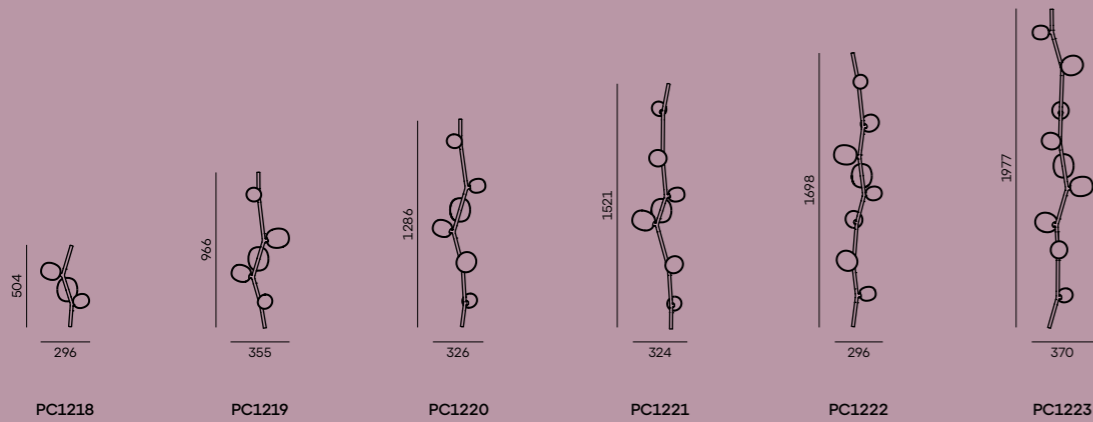

Canopy for Ivy Ceiling and Ivy Wall

IVY SINGLE

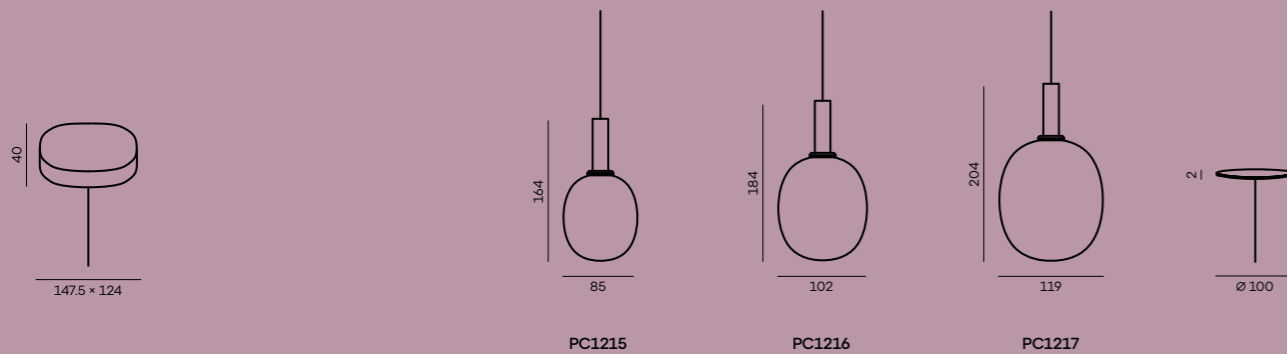

p. 157 | PH753
PC1060—PC1063—PC1064—PC1061—PC1059 (CGSU881, CCS2811, CCSC2812, CECL519, CEB1818)
 GLASS COLOUR: triplex opal (**CGC39**), light pink – transparent glass (**CGC46**), smoke grey – transparent glass (**CGC516**)
 GLASS SURFACE: acid-etched both side surface
 BODY FINISH: metal – anthracite grey matte powder coating with structure
 CANOPY FINISH: metal – anthracite grey matte powder coating with structure
 CABLE COLOUR: textile cable – black
 RECOMMENDED BULBS: 12V, G4, 1.2W, 2700K, 91lm, DIM

p. 158 | PH1394
PC1131 (CGC39, CGSU881, CCS2811, CECL2719, CEB1818)
 GLASS COLOUR: triplex opal
 GLASS SURFACE: acid-etched both side surface
 BODY FINISH: metal – anthracite grey matte powder coating with structure
 CABLE COLOUR: cable without textile – black
 RECOMMENDED BULBS: 12V, G4, 1.2W, 2700K, 91lm, DIM

p. 159 | PH1395
PC1132 (CGC39, CGSU881, CCS2809, CECL2719, CEB1818)
 GLASS COLOUR: triplex opal
 GLASS SURFACE: acid-etched both side surface
 BODY FINISH: metal – white matte powder coating with structure
 CABLE COLOUR: cable without textile – black
 RECOMMENDED BULBS: 12V, G4, 1.2W, 2700K, 91lm, DIM

p. 160—161 | PH1397
PC1069—PC1068 (CGC39, CGSU881, CCS2811, CCSC2812, CECL519, CEB1818)
 GLASS COLOUR: triplex opal
 GLASS SURFACE: acid-etched both side surface
 BODY FINISH: metal – anthracite grey matte powder coating with structure
 CANOPY FINISH: metal – anthracite grey matte powder coating with structure
 CABLE COLOUR: textile cable – black
 RECOMMENDED BULBS: 12V, G4, 1.2W, 2700K, 91lm, DIM

p. 162 | PH3797
PC1229 (CGC516, CGSU881, CCS2675, CEB1818)
 GLASS COLOUR: smoke grey – transparent glass
 GLASS SURFACE: acid-etched both side surface
 BODY FINISH: metal – anthracite grey matte powder coating
 RECOMMENDED BULBS: 12V, G4, 1.2W, 2700K, 91lm, DIM

163 | PH750
3×PC1060 (CGC39, CGSU881, CCS2809, CCSC2810, CECL521, CEB1818)
 GLASS COLOUR: triplex opal
 GLASS SURFACE: acid-etched both side surface
 BODY FINISH: metal – white matte powder coating with structure
 CANOPY FINISH: metal – white matte powder coating with structure
 CABLE COLOUR: textile cable – white
 RECOMMENDED BULBS: 12V, G4, 1.2W, 2700K, 91lm, DIM

p. 164 | PH1396
PC1068 (CGSU881, CCS2811, CCSC2812, CECL519, CEB1818)
 GLASS COLOUR: triplex opal (**CGC39**), smoke grey – transparent glass (**CGC516**), triplex opal (**CGC39**)
 GLASS SURFACE: acid-etched both side surface
 BODY FINISH: metal – anthracite grey matte powder coating with structure
 CANOPY FINISH: metal – anthracite grey matte powder coating with structure
 CABLE COLOUR: textile cable – black
 RECOMMENDED BULBS: 12V, G4, 1.2W, 2700K, 91lm, DIM

p. 165 | PH3871
PC1218 (CGC39, CGSU881, CCS2809, CEB1818)
 GLASS COLOUR: triplex opal
 GLASS SURFACE: acid-etched both side surface
 BODY FINISH: metal – white matte powder coating with structure
 RECOMMENDED BULBS: 12V, G4, 1.2W, 2700K, 91lm, DIM

p. 166 | PH3883
PC1217 (CGC46, CGSU881, CCS2809, CECL2772, CEB1818)
 GLASS COLOUR: light pink – transparent glass
 GLASS SURFACE: acid-etched both side surface
 BODY FINISH: metal – white matte powder coating with structure
 CABLE COLOUR: coaxial cable – silver
 RECOMMENDED BULBS: 12V, G4, 1.2W, 2700K, 91lm, DIM

p. 167 | PH4815
6×PC1215—6×PC1217 (CGSU881, CCS2809, CECL2772, CEB1818)
 GLASS COLOUR: light pink – transparent glass (**CGC46**), triplex opal (**CGC39**)
 GLASS SURFACE: acid-etched both side surface
 BODY FINISH: metal – white matte powder coating with structure
 CABLE COLOUR: coaxial cable – silver
 RECOMMENDED BULBS: 12V, G4, 1.2W, 2700K, 91lm, DIM

p. 259 | PH6259
PC1131 (CGC516, CGSU881, CCS2811, CEB1818)
 GLASS COLOUR: smoke grey – transparent glass
 GLASS SURFACE: acid-etched both side surface
 BODY FINISH: metal – anthracite grey matte powder coating with structure
 RECOMMENDED BULBS: 12V, G4, 1.2W, 2700K, 91lm, DIM

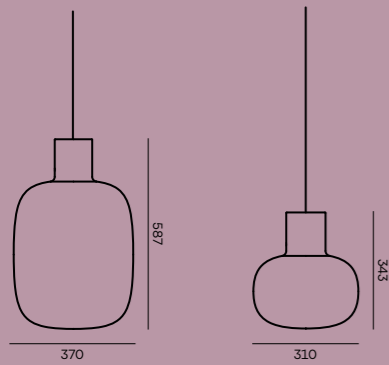

PC1130

PC1129

p. 169 | PH666

PC1130 (CGC23, CGSU66, CCS757, CCSC842, CECL1918, CEB2671)

GLASS COLOUR: transparent glass

GLASS SURFACE: glossy surface

BODY FINISH: American walnut – natural waxed

CANOPY FINISH: American walnut – natural waxed

CABLE COLOUR: textile cable – light grey

RECOMMENDED BULBS: 230V, LED, E27, 6W,

2000K, 200lm, RA90, DIM – FILAMENT LED

p. 170 | PH1388

PC1129 — PC1130 (CGC516, CGSU66, CCS775, CCSC843, CECL519, CEB2671)

GLASS COLOUR: smoke grey – transparent glass

GLASS SURFACE: glossy surface

BODY FINISH: aluminium

CANOPY FINISH: aluminium

CABLE COLOUR: textile cable – black

RECOMMENDED BULBS: 230V, LED, E27, 6W,

2000K, 200lm, RA90, DIM – FILAMENT LED

PC1129 (CGC23, CGSU66, CCS775, CCSC843, CECL519, CEB2671)

GLASS COLOUR: transparent glass

GLASS SURFACE: glossy surface

BODY FINISH: aluminium

CANOPY FINISH: aluminium

CABLE COLOUR: textile cable – black

RECOMMENDED BULBS: 230V, LED, E27, 6W,

2000K, 200lm, RA90, DIM – FILAMENT LED

p. 171 | PH668

PC1130 — PC1129 (CGC516, CGSU66, CCS757, CCSC842, CECL519, CEB2671)

GLASS COLOUR: smoke grey – transparent glass

GLASS SURFACE: glossy surface

BODY FINISH: American walnut – natural waxed

CANOPY FINISH: American walnut – natural waxed

CABLE COLOUR: textile cable – black

RECOMMENDED BULBS: 230V, LED, E27, 6W,

2000K, 200lm, RA90, DIM – FILAMENT LED

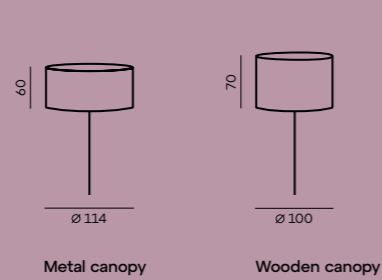

Metal canopy

Wooden canopy

p. 172—173 | PH670

PC1129 (CGC23, CGSU66, CCS584, CCSC896, CECL1918, CEB2671)

GLASS COLOUR: transparent glass

GLASS SURFACE: glossy surface

BODY FINISH: copper

CANOPY FINISH: copper

CABLE COLOUR: textile cable – light grey

RECOMMENDED BULBS: 230V, LED, E27, 6W,

2000K, 200lm, RA90, DIM – FILAMENT LED

PC1129 (CGC516, CGSU66, CCS775, CCSC843, CECL519, CEB2671)

GLASS COLOUR: smoke grey – transparent glass

GLASS SURFACE: glossy surface

BODY FINISH: aluminium

CANOPY FINISH: aluminium

CABLE COLOUR: textile cable – black

RECOMMENDED BULBS: 230V, LED, E27, 6W,

2000K, 200lm, RA90, DIM – FILAMENT LED

PC1130 (CGC538, CGSU66, CCS584, CCSC896, CECL1918, CEB2671)

GLASS COLOUR: smoke brown – transparent glass

GLASS SURFACE: glossy surface

BODY FINISH: copper

CANOPY FINISH: copper

CABLE COLOUR: textile cable – light grey

RECOMMENDED BULBS: 230V, LED, E27, 6W,

2000K, 200lm, RA90, DIM – FILAMENT LED

p. 174 | PH669

PC1129 (CGC538, CGSU66, CCS584, CCSC896, CECL1918, CEB2671)

GLASS COLOUR: smoke brown – transparent glass

GLASS SURFACE: glossy surface

BODY FINISH: copper

CANOPY FINISH: copper

CABLE COLOUR: textile cable – light grey

RECOMMENDED BULBS: 230V, LED, E27, 6W,

2000K, 200lm, RA90, DIM – FILAMENT LED

p. 175 | PH1392

PC1130 — 2×PC1129 (CGC516, CGSU66, CCS757, CCSC842, CECL519, CEB2671)

GLASS COLOUR: smoke grey – transparent glass

GLASS SURFACE: glossy surface

BODY FINISH: American walnut – natural waxed

CANOPY FINISH: American walnut – natural waxed

CABLE COLOUR: textile cable – black

RECOMMENDED BULBS: 230V, LED, E27, 6W,

2000K, 200lm, RA90, DIM – FILAMENT LED

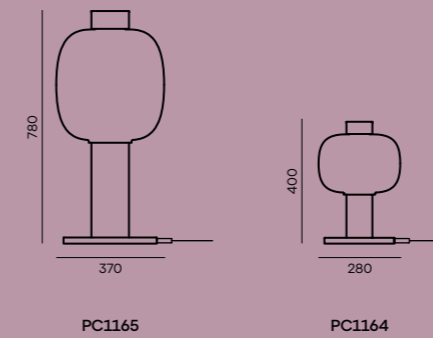

PC1165

PC1164

p. 177 | PH2562

PC1164 (CGC38, CGSU66, CCS2749, CECL519, CEB2750)

GLASS COLOUR: opaline – transparent glass

GLASS SURFACE: glossy surface

BODY FINISH: grey metallic

CABLE COLOUR: textile cable – black

RECOMMENDED BULBS: 230V, E27, 12W, 2800K,

750lm, RA90, 360°, DIM

p. 178—179 | PH3865

PC1164 (CGC516, CGSU66, CCS846, CECL519, CEB2750)

GLASS COLOUR: smoke grey – transparent glass

GLASS SURFACE: glossy surface

BODY FINISH: metal – black matte powder coating

CABLE COLOUR: textile cable – black

RECOMMENDED BULBS: 230V, E27, 12W, 2800K,

750lm, RA90, 360°, DIM

PC1164 (CGC538, CGSU66, CCS2748, CECL519, CEB2750)

GLASS COLOUR: smoke brown – transparent glass

GLASS SURFACE: glossy surface

BODY FINISH: copper metallic

CABLE COLOUR: textile cable – black

RECOMMENDED BULBS: 230V, E27, 12W, 2800K,

750lm, RA90, 360°, DIM

PC1164 (CGC39, CGSU66, CCS2749, CECL519, CEB2750)

GLASS COLOUR: triplex opal

GLASS SURFACE: glossy surface

BODY FINISH: grey metallic

CABLE COLOUR: textile cable – black

RECOMMENDED BULBS: 230V, E27, 12W, 2800K,

750lm, RA90, 360°, DIM

p. 180—181 | PH3855

PC1165 (CGC538, CGSU66, CCS2748, CECL519, CEB2750)

GLASS COLOUR: smoke brown – transparent glass

GLASS SURFACE: glossy surface

BODY FINISH: copper metallic

CABLE COLOUR: textile cable – black

RECOMMENDED BULBS: 230V, E27, 12W, 2800K,

750lm, RA90, 360°, DIM

p. 182 | PH3794

PC1164 (CGC39, CGSU66, CCS846, CECL519, CEB2750)

GLASS COLOUR: triplex opal

GLASS SURFACE: glossy surface

BODY FINISH: metal – black matte powder coating

CABLE COLOUR: textile cable – black

RECOMMENDED BULBS: 230V, E27, 12W, 2800K,

750lm, RA90, 360°, DIM

PC1165 (CGC538, CGSU66, CCS2748, CECL519, CEB2750)

GLASS COLOUR: smoke brown – transparent glass

GLASS SURFACE: glossy surface

BODY FINISH: copper metallic

CABLE COLOUR: textile cable – black

RECOMMENDED BULBS: 230V, E27, 12W, 2800K,

750lm, RA90, 360°, DIM

PC1165 (CGC516, CGSU66, CCS846, CECL519, CEB2750)

GLASS COLOUR: smoke grey – transparent glass

GLASS SURFACE: glossy surface

BODY FINISH: metal – black matte powder coating

CABLE COLOUR: textile cable – black

RECOMMENDED BULBS: 230V, E27, 12W, 2800K,

750lm, RA90, 360°, DIM

p. 183 | PH2560

PC1164 (CGC39, CGSU66, CCS2748, CECL519, CEB2750)

GLASS COLOUR: triplex opal

GLASS SURFACE: glossy surface

BODY FINISH: copper metallic

CABLE COLOUR: textile cable – black

RECOMMENDED BULBS: 230V, E27, 12W, 2800K,

750lm, RA90, 360°, DIM

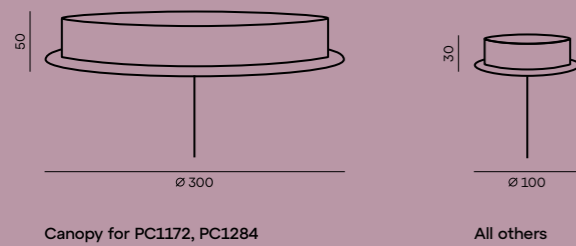
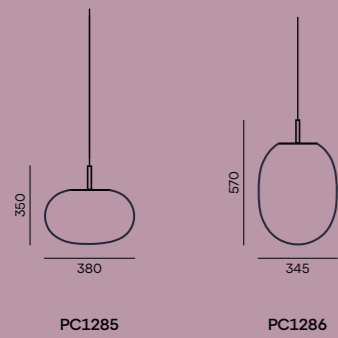
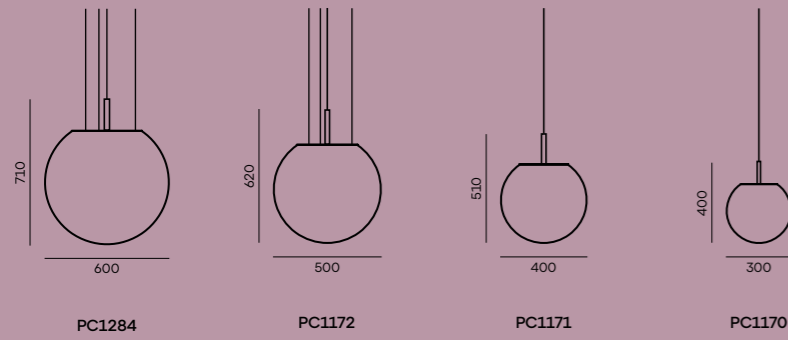

p. 185 | PH6995
PC1171 (CGC39, CGSU67, CCS846, CCSC619, CECL519)
 GLASS COLOUR: triplex opal
 GLASS SURFACE: acid-etched outside surface
 BODY FINISH: metal – black matte powder coating
 CANOPY FINISH: metal – black matte powder coating
 CABLE COLOUR: textile cable – black

p. 186—187 | PH3803
PC1168 (CGC39, CGSU881, CCS845, CCSC618, CECL521)
 GLASS COLOUR: triplex opal
 GLASS SURFACE: acid-etched both side surface
 BODY FINISH: metal – white matte powder coating
 CANOPY FINISH: metal – white matte powder coating
 CABLE COLOUR: textile cable – white
PC1247 (CGC39, CGSU881, CCS845, CCSC618, CECL521)
 GLASS COLOUR: triplex opal
 GLASS SURFACE: acid-etched both side surface
 BODY FINISH: metal – white matte powder coating
 CANOPY FINISH: metal – white matte powder coating
 CABLE COLOUR: textile cable – white

PC1169 (CGC39, CGSU881, CCS846, CCSC619, CECL519)
 GLASS COLOUR: triplex opal
 GLASS SURFACE: acid-etched both side surface
 BODY FINISH: metal – black matte powder coating
 CANOPY FINISH: metal – black matte powder coating
 CABLE COLOUR: textile cable – black
PC1172 (CGC39, CGSU67, CCS845, CCSC618, CECL521)
 GLASS COLOUR: triplex opal
 GLASS SURFACE: acid-etched outside surface
 BODY FINISH: metal – white matte powder coating
 CANOPY FINISH: metal – white matte powder coating
 CABLE COLOUR: textile cable – white

PC1246 (CGC39, CGSU881, CCS845, CCSC618, CECL521)
 GLASS COLOUR: triplex opal
 GLASS SURFACE: acid-etched both side surface
 BODY FINISH: metal – white matte powder coating
 CANOPY FINISH: metal – white matte powder coating
 CABLE COLOUR: textile cable – white
PC1170 (CGC39, CGSU881, CCS846, CCSC619, CECL519)
 GLASS COLOUR: triplex opal
 GLASS SURFACE: acid-etched both side surface
 BODY FINISH: metal – black matte powder coating
 CANOPY FINISH: metal – black matte powder coating
 CABLE COLOUR: textile cable – black

p. 188 | PH7566
PC1171 (CGC39, CGSU881, CCS846, CCSC619, CECL519)
 GLASS COLOUR: triplex opal
 GLASS SURFACE: acid-etched both side surface
 BODY FINISH: metal – black matte powder coating
 CANOPY FINISH: metal – black matte powder coating
 CABLE COLOUR: textile cable – black

p. 189 | PH3799
PC1170 (CGC39, CGSU881, CCS846, CCSC619, CECL519)
 GLASS COLOUR: triplex opal
 GLASS SURFACE: acid-etched both side surface
 BODY FINISH: metal – black matte powder coating
 CANOPY FINISH: metal – black matte powder coating
 CABLE COLOUR: textile cable – black
PC1246 (CGC39, CGSU881, CCS846, CCSC619, CECL519)
 GLASS COLOUR: triplex opal
 GLASS SURFACE: acid-etched both side surface
 BODY FINISH: metal – black matte powder coating
 CANOPY FINISH: metal – black matte powder coating
 CABLE COLOUR: textile cable – black

PC1247 (CGC39, CGSU881, CCS846, CCSC619, CECL519)
 GLASS COLOUR: triplex opal
 GLASS SURFACE: acid-etched both side surface
 BODY FINISH: metal – black matte powder coating
 CANOPY FINISH: metal – black matte powder coating
 CABLE COLOUR: textile cable – black
PC1172 (CGC39, CGSU67, CCS846, CCSC619, CECL519)
 GLASS COLOUR: triplex opal
 GLASS SURFACE: acid-etched outside surface
 BODY FINISH: metal – black matte powder coating
 CANOPY FINISH: metal – black matte powder coating
 CABLE COLOUR: textile cable – black

PC1168 (CGC39, CGSU881, CCS846, CCSC619, CECL519)
 GLASS COLOUR: triplex opal
 GLASS SURFACE: acid-etched both side surface
 BODY FINISH: metal – black matte powder coating
 CANOPY FINISH: metal – black matte powder coating
 CABLE COLOUR: textile cable – black
PC1169 (CGC39, CGSU881, CCS846, CCSC619, CECL519)
 GLASS COLOUR: triplex opal
 GLASS SURFACE: acid-etched both side surface
 BODY FINISH: metal – black matte powder coating
 CANOPY FINISH: metal – black matte powder coating
 CABLE COLOUR: textile cable – black

p. 190—191 | PH7392
PC1285—PC1286 (CGC39, CGSU67, CCS846, CCSC619, CECL519)
 GLASS COLOUR: triplex opal
 GLASS SURFACE: acid-etched outside surface
 BODY FINISH: metal – black matte powder coating
 CANOPY FINISH: metal – black matte powder coating
 CABLE COLOUR: textile cable – black
PC1170 (CGC39, CGSU881, CCS846, CCSC619, CECL519)
 GLASS COLOUR: triplex opal
 GLASS SURFACE: acid-etched both side surface
 BODY FINISH: metal – black matte powder coating
 CANOPY FINISH: metal – black matte powder coating
 CABLE COLOUR: textile cable – black

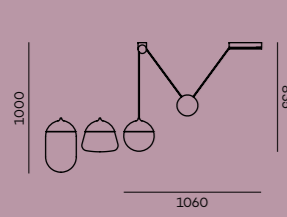

PC1234

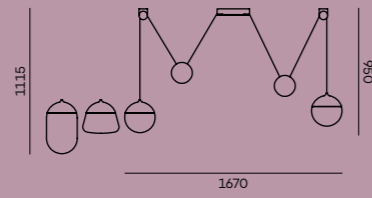

PC1235

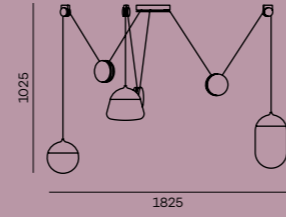

PC1236

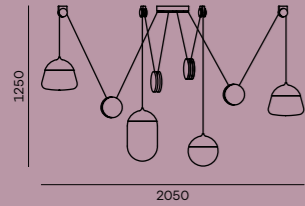

PC1237

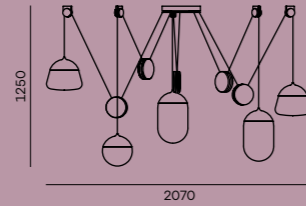

PC1238

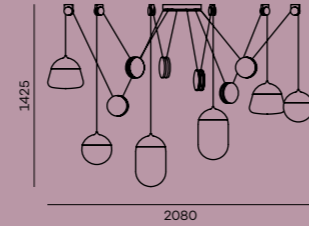

PC1239

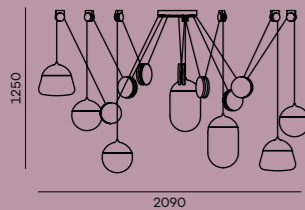

PC1240

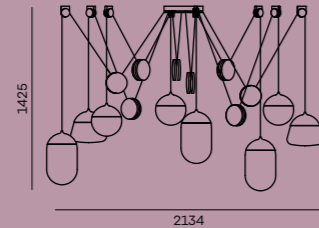

PC1241

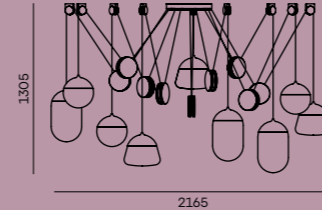

PC1242

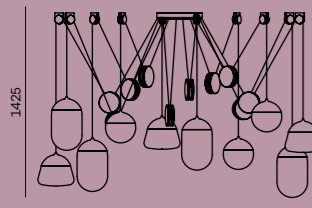

PC1243

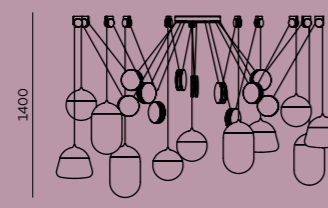

PC1244

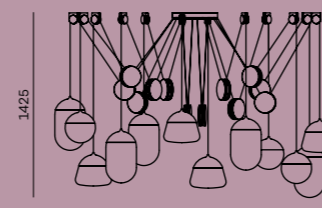

PC1245

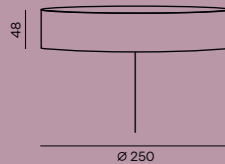

Canopy
for PC1234-PC1237

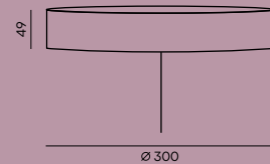

Canopy
for PC1238-PC1241

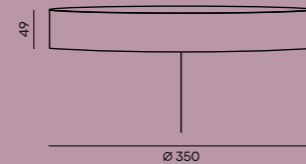

Canopy
for PC1242-PC1245

p. 203 | PH5711
PC1234 (CCSC618)
 CANOPY FINISH:
 metal – white matte powder coating
(CGC39, CGSU881, CCS845, CECL521, LEDS2775)
 GLASS COLOUR: triplex opal
 GLASS SURFACE: acid-etched both side surface
 BODY FINISH: metal – white matte powder coating
 CABLE COLOUR: textile cable – white
 LED SOURCE: 300mA, LED, 15W, 2700K, RA90, DIM

p. 204—205 | PH5701
PC1242 (CCSC618)
 CANOPY FINISH:
 metal – white matte powder coating
(CGC39, CGSU881, CCS845, CECL521, LEDS2775)
 GLASS COLOUR: triplex opal
 GLASS SURFACE: acid-etched both side surface
 BODY FINISH: metal – white matte powder coating
 CABLE COLOUR: textile cable – white
 LED SOURCE: 300mA, LED, 15W, 2700K, RA90, DIM

p. 206 | PH5702
PC1237 (CCSC618)
 CANOPY FINISH:
 metal – white matte powder coating
(CGC39, CGSU881, CCS845, CECL521, LEDS2775)
 GLASS COLOUR: triplex opal
 GLASS SURFACE: acid-etched both side surface
 BODY FINISH: metal – white matte powder coating
 CABLE COLOUR: textile cable – white
 LED SOURCE: 300mA, LED, 15W, 2700K, RA90, DIM

p. 207 | PH3634
PC1236 (CCSC619)
 CANOPY FINISH:
 metal – black matte powder coating
(CGC516, CGSU881, CCS846, CECL519, LEDS2775)
 GLASS COLOUR: smoke grey – transparent glass
 GLASS SURFACE: acid-etched both side surface
 BODY FINISH: metal – black matte powder coating
 CABLE COLOUR: textile cable – black
 LED SOURCE: 300mA, LED, 15W, 2700K, RA90, DIM

p. 208—209 | PH1659
PC1239 (CCSC619)
 CANOPY FINISH:
 metal – black matte powder coating
(CGC516, CGSU881, CCS846, CECL519, LEDS2775)
 GLASS COLOUR: smoke grey – transparent glass
 GLASS SURFACE: acid-etched both side surface
 BODY FINISH: metal – black matte powder coating
 CABLE COLOUR: textile cable – black
 LED SOURCE: 300mA, LED, 15W, 2700K, RA90, DIM

ORBIS

p. 15 | PH8277

PC1289 (CGC516, CGSU66, CCS846, CCSC619, CECL519, LEDS2866)

GLASS COLOUR: smoke grey – transparent glass
 GLASS SURFACE: glossy surface
 BODY FINISH: metal – black matte powder coating
 CANOPY FINISH: metal – black matte powder coating
 CABLE COLOUR: textile cable – black
 LED SOURCE: 24V, LED, 2.3W, 2700K, 365lm, RA90+, DIM

PC1290 (CGC516, CGSU66, CCS846, CCSC619, CECL519, LEDS2867)

GLASS COLOUR: smoke grey – transparent glass
 GLASS SURFACE: glossy surface
 BODY FINISH: metal – black matte powder coating
 CANOPY FINISH: metal – black matte powder coating
 CABLE COLOUR: textile cable – black
 LED SOURCE: 24V, LED, 4.3W, 2700K, 609lm, RA90+, DIM

PC1291 (CGC516, CGSU66, CCS846, CCSC619, CECL519, LEDS2868)

GLASS COLOUR: smoke grey – transparent glass
 GLASS SURFACE: glossy surface
 BODY FINISH: metal – black matte powder coating
 CANOPY FINISH: metal – black matte powder coating
 CABLE COLOUR: textile cable – black
 LED SOURCE: 24V, LED, 15.7W, 2700K, 2193lm, RA90+, DIM

SFERA PORTABLE

p. 15 | PH8277

PC1271 (CGC39, CGSU881, CCS68, CSFB2840, CECL2837, LEDS2870)

GLASS COLOUR: triplex opal
 GLASS SURFACE: acid-etched both side surface
 BODY FINISH: brushed stainless steel
 BASE FINISH: high performance concrete – natural
 CABLE COLOUR: black charging cable
 USB 2/USB-C, 5V
 LED SOURCE: 12V, LED, 2.8W, 2700K, 310lm, RA80+, DIM

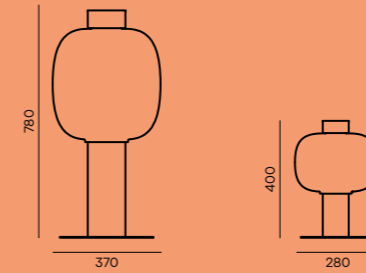

PC1167

PC1166

p. 227 | PH2574

PC1166 (CGC516, CGSU66, CCS846, CEB2750)

GLASS COLOUR: smoke grey – transparent glass
 GLASS SURFACE: glossy surface
 BODY FINISH: metal – black matte powder coating
 RECOMMENDED BULBS: 230V, E27, 12W, 2800K, 750lm, RA90, 360°, DIM

p. 228 | PH2571

PC1166 (CGC516, CGSU66, CCS2748, CEB2750)

GLASS COLOUR: smoke grey – transparent glass
 GLASS SURFACE: glossy surface
 BODY FINISH: copper metallic
 RECOMMENDED BULBS: 230V, E27, 12W, 2800K, 750lm, RA90, 360°, DIM

p. 229 | PH3556

PC1166 (CGC38, CGSU66, CCS2749, CEB2750)

GLASS COLOUR: opaline – transparent glass
 GLASS SURFACE: glossy surface
 BODY FINISH: grey metallic
 RECOMMENDED BULBS: 230V, E27, 12W, 2800K, 750lm, RA90, 360°, DIM

PC1166 (CGC538, CGSU66, CCS2748, CEB2750)

GLASS COLOUR: smoke brown – transparent glass
 GLASS SURFACE: glossy surface
 BODY FINISH: copper metallic
 RECOMMENDED BULBS: 230V, E27, 12W, 2800K, 750lm, RA90, 360°, DIM

p. 230—231 | PH2576

PC1166 (CGC516, CGSU66, CCS846, CEB2750)

GLASS COLOUR: smoke grey – transparent glass
 GLASS SURFACE: glossy surface
 BODY FINISH: metal – black matte powder coating
 RECOMMENDED BULBS: 230V, E27, 12W, 2800K, 750lm, RA90, 360°, DIM

PC1166 (CGC538, CGSU66, CCS2748, CEB2750)

GLASS COLOUR: smoke brown – transparent glass
 GLASS SURFACE: glossy surface
 BODY FINISH: copper metallic
 RECOMMENDED BULBS: 230V, E27, 12W, 2800K, 750lm, RA90, 360°, DIM
PC1166 (CGC38, CGSU66, CCS2749, CEB2750)
 GLASS COLOUR: opaline – transparent glass
 GLASS SURFACE: glossy surface
 BODY FINISH: grey metallic
 RECOMMENDED BULBS: 230V, E27, 12W, 2800K, 750lm, RA90, 360°, DIM

p. 232 | PH3492

PC1167—PC1166 (CGC538, CGSU66, CCS2748, CEB2750)

GLASS COLOUR: smoke brown – transparent glass
 GLASS SURFACE: glossy surface
 BODY FINISH: copper metallic
 RECOMMENDED BULBS: 230V, E27, 12W, 2800K, 750lm, RA90, 360°, DIM

p. 233 | PH3853

PC1167 (CGC516, CGSU66, CCS846, CEB2750)

GLASS COLOUR: smoke grey – transparent glass
 GLASS SURFACE: glossy surface
 BODY FINISH: metal – black matte powder coating
 RECOMMENDED BULBS: 230V, E27, 12W, 2800K, 750lm, RA90, 360°, DIM

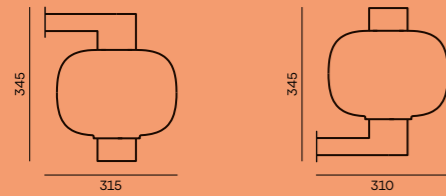

PC1280

PC1251

p. 235 | PH7401

PC1251 (CGC516, CGSU66, CCS2749, CEB2750)
 GLASS COLOUR: smoke grey – transparent glass
 GLASS SURFACE: glossy surface
 BODY FINISH: grey metallic
 RECOMMENDED BULBS: 230V, E27, 11W, 2700K,
 1250lm, RA90, 360°, DIM

p. 237 | PH7405

PC1280 (CGC538, CGSU66, CCS2748, CEB2750)
 GLASS COLOUR: smoke brown – transparent glass
 GLASS SURFACE: glossy surface
 BODY FINISH: copper metallic
 RECOMMENDED BULBS: 230V, E27, 11W, 2700K,
 1250lm, RA90, 360°, DIM

p. 236 | PH7403

PC1251 (CGC38, CGSU66, CCS2749, CEB2750)
 GLASS COLOUR: opaline – transparent glass
 GLASS SURFACE: glossy surface
 BODY FINISH: grey metallic
 RECOMMENDED BULBS: 230V, E27, 11W, 2700K,
 1250lm, RA90, 360°, DIM

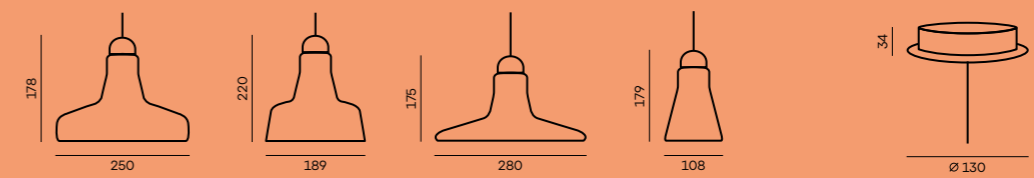

PC1160

PC1162

PC1161

PC1163

Ø 130

p. 239 | PH2267

PC1163—PC1161—PC1160—PC1162
(CGC516, CGSU66, CCS1948, CCSC974,
CECL2758, CEB2761)
 GLASS COLOUR: smoke grey – transparent glass
 GLASS SURFACE: glossy surface
 BODY FINISH: black anodized
 CANOPY FINISH: brushed stainless steel
 CABLE COLOUR: silicone cable – black
 RECOMMENDED BULBS: 230V, LED, GU10, 6.5W,
 2700K, DIM

p. 242—243 | PH2960

2×PC1163—PC1160—PC1162
(CGC38, CGSU66, CCS1917, CCSC974,
CECL2757, CEB2761)
 GLASS COLOUR: opaline – transparent glass
 GLASS SURFACE: glossy surface
 BODY FINISH: silver anodized
 CANOPY FINISH: brushed stainless steel
 CABLE COLOUR: silicone cable – white
 RECOMMENDED BULBS: 230V, LED, GU10, 6.5W,
 2700K, DIM

p. 240 | PH2269

PC1162—PC1163 (CGC38, CGSU66,
CCS1917, CCSC974, CECL2757, CEB2761)
 GLASS COLOUR: opaline – transparent glass
 GLASS SURFACE: glossy surface
 BODY FINISH: silver anodized
 CANOPY FINISH: brushed stainless steel
 CABLE COLOUR: silicone cable – white
 RECOMMENDED BULBS: 230V, LED, GU10, 6.5W,
 2700K, DIM

p. 241 | PH2958

PC1160—2×PC1163—PC1161—PC1162
(CGC38, CGSU66, CCS1917, CCSC974,
CECL2757, CEB2761)
 GLASS COLOUR: opaline – transparent glass
 GLASS SURFACE: glossy surface
 BODY FINISH: silver anodized
 CANOPY FINISH: brushed stainless steel
 CABLE COLOUR: silicone cable – white
 RECOMMENDED BULBS: 230V, LED, GU10, 6.5W,
 2700K, DIM

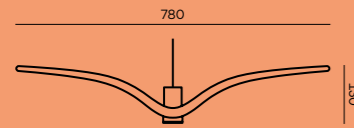

PC1111

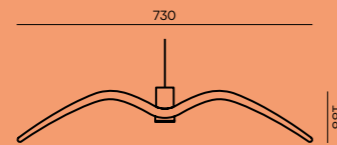

PC1112

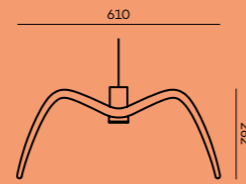

PC1113

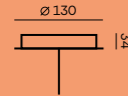

p. 245 | PH2383
PC1113 — PC1112
(CGC1480, CCS1948, CCSC974, CECL2758, CEB2761)
 GLASS COLOUR: smoke grey
 BROKISGLASS matte
 BODY FINISH: black anodized
 CANOPY FINISH: brushed stainless steel
 CABLE COLOUR: silicone cable – black
 RECOMMENDED BULBS: 230V, LED, GU10, 6.5W, 2700K, DIM

p. 246 — 247 | PH3100
PC1111 — PC1112 — PC1113
(CGC772, CCS1917, CCSC974, CECL2757, CEB2761)
 GLASS COLOUR: opal – opaque glass – massif
 BODY FINISH: silver anodized
 CANOPY FINISH: brushed stainless steel
 CABLE COLOUR: silicone cable – white
 RECOMMENDED BULBS: 230V, LED, GU10, 6.5W, 2700K, DIM

p. 248 | PH2265
PC1111 — PC1113 — PC1112
(CGC882, CCS1948, CCSC974, CECL2758, CEB2761)
 GLASS COLOUR: smoke grey – massif
 BODY FINISH: black anodized
 CANOPY FINISH: brushed stainless steel
 CABLE COLOUR: silicone cable – black
 RECOMMENDED BULBS: 230V, LED, GU10, 6.5W, 2700K, DIM

p. 249 | PH2359
3×PC1113 (CGC1478, CCS1917, CCSC974, CECL2757, CEB2761)
 GLASS COLOUR: triplex opal BROKISGLASS matte
 BODY FINISH: silver anodized
 CANOPY FINISH: brushed stainless steel
 CABLE COLOUR: silicone cable – white
 RECOMMENDED BULBS: 230V, LED, GU10, 6.5W, 2700K, DIM



PC1249
Cilindro



PC1250
SmallCilindro

p. 253 | PH8180
PC1250 (CGC23, CGSU66, CCS69, CECL2838, CRP970, LEDS2864)
 GLASS COLOUR: transparent glass
 GLASS SURFACE: glossy surface
 BODY FINISH: brass
 CABLE COLOUR: black charging cable
 USB 2/Mag, 5V
 ROPE: rope – natural
 LED SOURCE: 244mA, LED, 2.7W, 2700K, 580lm, RA80+, DIM
PC1249 (CGC538, CGSU66, CCS69, CECL2838, CRP970, LEDS2836)
 GLASS COLOUR: smoke brown – transparent glass
 GLASS SURFACE: glossy surface
 BODY FINISH: brass
 CABLE COLOUR: black charging cable
 USB 2/Mag, 5V
 ROPE: rope – natural
 LED SOURCE: 240mA, LED, 4W, 2700K, 950lm, RA80+, DIM

p. 254 | PH6873
PC1249 (CGC516, CGSU66, CCS2673, CRP970, CECL2838, LEDS2836)
 GLASS COLOUR: smoke grey – transparent glass
 GLASS SURFACE: glossy surface
 BODY FINISH: black matte powder coating with structure
 ROPE: natural
 CABLE COLOUR: black charging cable
 USB 2/Mag, 5V
 LED SOURCE: 240mA, LED, 4W, 2700K, 950lm, RA80+, DIM

p. 255 | PH6566
PC1249 (CGC516, CGSU66, CCS2673, CRP970, CECL2838, LEDS2836)
 GLASS COLOUR: smoke grey – transparent glass
 GLASS SURFACE: glossy surface
 BODY FINISH: black matte powder coating with structure
 ROPE: natural
 CABLE COLOUR: black charging cable
 USB 2/Mag, 5V
 LED SOURCE: 240mA, LED, 4W, 2700K, 950lm, RA80+, DIM

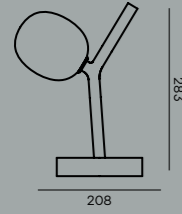

PC1233

p. 257 | PH6260
PC1233 (CGC46, CGSU881, CCS2809, CECL2837, CEB1818)
 GLASS COLOUR: light pink – transparent glass
 GLASS SURFACE: acid-etched both side surface
 BODY FINISH: metal – white matte powder coating with structure
 CABLE COLOUR: black charging cable
 USB 2/USB-C, 5V
 RECOMMENDED BULBS: 12V, G4, 1.2W, 2700K, 91lm, DIM

p. 258 | PH6565
PC1233 (CGC516, CGSU881, CCS2811, CECL2837, CEB1818)
 GLASS COLOUR: smoke grey – transparent glass
 GLASS SURFACE: acid-etched both side surface
 BODY FINISH: metal – anthracite grey matte powder coating with structure
 CABLE COLOUR: black charging cable
 USB 2/USB-C, 5V
 RECOMMENDED BULBS: 12V, G4, 1.2W, 2700K, 91lm, DIM
PC1233 (CGC39, CGSU881, CCS2809, CECL2837, CEB1818)
 GLASS COLOUR: triplex opal
 GLASS SURFACE: acid-etched both side surface
 BODY FINISH: metal – white matte powder coating with structure
 CABLE COLOUR: black charging cable
 USB 2/USB-C, 5V
 RECOMMENDED BULBS: 12V, G4, 1.2W, 2700K, 91lm, DIM

p. 259 | PH6259
PC1233 (CGC39, CGSU881, CCS2809, CECL2837, CEB1818)
 GLASS COLOUR: triplex opal
 GLASS SURFACE: acid-etched both side surface
 BODY FINISH: metal – white matte powder coating with structure
 CABLE COLOUR: black charging cable
 USB 2/USB-C, 5V
 RECOMMENDED BULBS: 12V, G4, 1.2W, 2700K, 91lm, DIM

p. 260 — 261 | PH6261
PC1233 (CGC46, CGSU881, CCS2809, CECL2837, CEB1818)
 GLASS COLOUR: light pink – transparent glass
 GLASS SURFACE: acid-etched both side surface
 BODY FINISH: metal – white matte powder coating with structure
 CABLE COLOUR: black charging cable
 USB 2/USB-C, 5V
 RECOMMENDED BULBS: 12V, G4, 1.2W, 2700K, 91lm, DIM
PC1233 (CGC516, CGSU881, CCS2809, CECL2837, CEB1818)
 GLASS COLOUR: smoke grey – transparent glass
 GLASS SURFACE: acid-etched both side surface
 BODY FINISH: metal – white matte powder coating with structure
 CABLE COLOUR: black charging cable
 USB 2/USB-C, 5V
 RECOMMENDED BULBS: 12V, G4, 1.2W, 2700K, 91lm, DIM

PC1233 (CGC39, CGSU881, CCS2809, CECL2837, CEB1818)
 GLASS COLOUR: triplex opal
 GLASS SURFACE: acid-etched both side surface
 BODY FINISH: metal – white matte powder coating with structure
 CABLE COLOUR: black charging cable
 USB 2/USB-C, 5V
 RECOMMENDED BULBS: 12V, G4, 1.2W, 2700K, 91lm, DIM

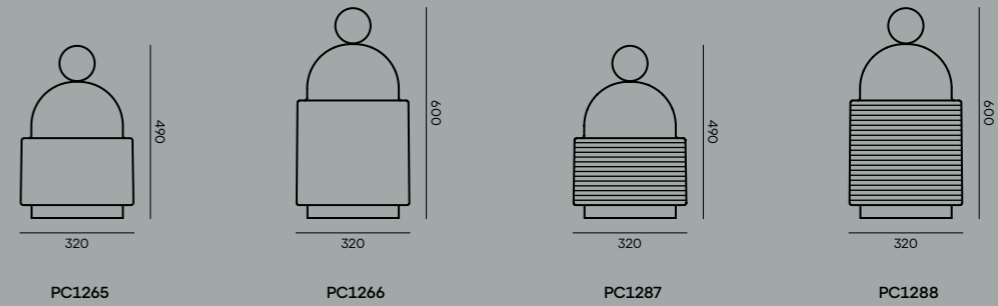

PC1265

PC1266

PC1287

PC1288

p. 263 | PH7476
PC1265 (CGC516, CGSU66, CCS2673, CECL2838, LEDS2836)
 GLASS COLOUR: smoke grey – transparent glass
 GLASS SURFACE: glossy surface
 BODY FINISH: metal – black matte powder coating with structure
 CABLE COLOUR: black charging cable
 USB 2/Mag, 5V
 LED SOURCE: 240mA, LED, 4W, 2700K, 950lm, RA80+, DIM

p. 264 and Cover page | PH7444
PC1288 (CGC516, CGSU66, CCS69, CECL2838, LEDS2836)
 GLASS COLOUR: smoke grey – transparent glass
 GLASS SURFACE: glossy surface
 BODY FINISH: brass
 CABLE COLOUR: black charging cable
 USB 2/Mag, 5V
 LED SOURCE: 240mA, LED, 4W, 2700K, 950lm, RA80+, DIM
PC1266 (CGC516, CGSU66, CCS2673, CECL2838, LEDS2836)
 GLASS COLOUR: smoke grey – transparent glass
 GLASS SURFACE: glossy surface
 BODY FINISH: metal – black matte powder coating with structure
 CABLE COLOUR: black charging cable
 USB 2/Mag, 5V
 LED SOURCE: 240mA, LED, 4W, 2700K, 950lm, RA80+, DIM
PC1265 (CGC38, CGSU66, CCS584, CECL2838, LEDS2836)
 GLASS COLOUR: opaline – transparent glass
 GLASS SURFACE: glossy surface
 BODY FINISH: copper

CABLE COLOUR: black charging cable
 USB 2/Mag, 5V
 LED SOURCE: 240mA, LED, 4W, 2700K, 950lm, RA80+, DIM

p. 265 | PH7474
PC1266 (CGC23, CGSU66, CCS68, CECL2838, LEDS2836)
 GLASS COLOUR: transparent glass
 GLASS SURFACE: glossy surface
 BODY FINISH: brushed stainless steel
 CABLE COLOUR: black charging cable
 USB 2/Mag, 5V
 LED SOURCE: 240mA, LED, 4W, 2700K, 950lm, RA80+, DIM

p. 266–267 | PH7490
PC1266 (CGC516, CGSU66, CCS2673, CECL2838, LEDS2836)
 GLASS COLOUR: smoke grey – transparent glass
 GLASS SURFACE: glossy surface
 BODY FINISH: metal – black matte powder coating with structure
 CABLE COLOUR: black charging cable
 USB 2/Mag, 5V
 LED SOURCE: 240mA, LED, 4W, 2700K, 950lm, RA80+, DIM
PC1265 (CGC38, CGSU66, CCS584, CECL2838, LEDS2836)
 GLASS COLOUR: opaline – transparent glass
 GLASS SURFACE: glossy surface
 BODY FINISH: copper
 CABLE COLOUR: black charging cable
 USB 2/Mag, 5V
 LED SOURCE: 240mA, LED, 4W, 2700K, 950lm, RA80+, DIM

p. 268 | PH7648
PC1288 (CGC516, CGSU66, CCS69, CECL2838, LEDS2836)
 GLASS COLOUR: smoke grey – transparent glass
 GLASS SURFACE: glossy surface
 BODY FINISH: brass
 CABLE COLOUR: black charging cable
 USB 2/Mag, 5V
 LED SOURCE: 240mA, LED, 4W, 2700K, 950lm, RA80+, DIM

p. 269 | PH7647
PC1288 (CGC516, CGSU66, CCS69, CECL2838, LEDS2836)
 GLASS COLOUR: smoke grey – transparent glass
 GLASS SURFACE: glossy surface
 BODY FINISH: brass
 CABLE COLOUR: black charging cable
 USB 2/Mag, 5V
 LED SOURCE: 240mA, LED, 4W, 2700K, 950lm, RA80+, DIM

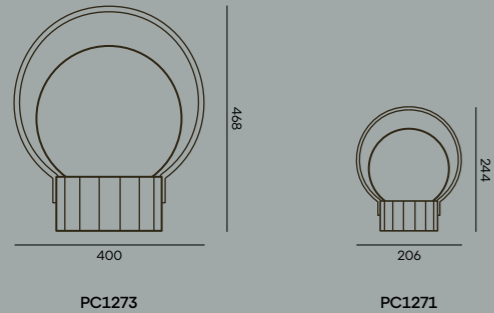

p. 271 | PH7633
PC1271 (CGC516, CGSU66, CCS846, CSFB2840, CECL2837, LEDS2845)
 GLASS COLOUR: smoke grey – transparent glass
 GLASS SURFACE: glossy surface
 BODY FINISH: metal – black matte powder coating
 BASE FINISH: high performance concrete – natural
 CABLE COLOUR: black charging cable
 USB 2/USB–C, 5V
 LED SOURCE: 12V, LED, 4W, 2700K, RA80+, DIM

p. 272—273 | PH7606
PC1271—PC1273 (CGC516, CGSU66, CCS846, CSFB2840, CECL2837, LEDS2845)
 GLASS COLOUR: smoke grey – transparent glass
 GLASS SURFACE: glossy surface
 BODY FINISH: metal – black matte powder coating
 BASE FINISH: high performance concrete – natural
 CABLE COLOUR: black charging cable
 USB 2/USB–C, 5V
 LED SOURCE: 12V, LED, 4W, 2700K, RA80+, DIM

p. 274 | PH7459
PC1273—PC1271 (CGC39, CGSU881, CCS68, CSFB2840, CECL2837, LEDS2845)
 GLASS COLOUR: triplex opal
 GLASS SURFACE: acid-etched both side surface
 BODY FINISH: brushed stainless steel
 BASE FINISH: high performance concrete – natural
 CABLE COLOUR: black charging cable
 USB 2/USB–C, 5V
 LED SOURCE: 12V, LED, 4W, 2700K, RA80+, DIM

p. 275 | PH8109
PC1271 (CGC516, CGSU66, CCS68, CSFB2842, CECL2837, LEDS2845)
 GLASS COLOUR: smoke grey – transparent glass
 GLASS SURFACE: glossy surface
 BODY FINISH: brushed stainless steel
 BASE FINISH: high performance concrete – terracotta
 CABLE COLOUR: black charging cable
 USB 2/USB–C, 5V
 LED SOURCE: 12V, LED, 4W, 2700K, RA80+, DIM

p. 276—277 | PH7558
PC1273 (CGC516, CGSU66, CCS846, CSFB2840, CECL2837, LEDS2845)
 GLASS COLOUR: smoke grey – transparent glass
 GLASS SURFACE: glossy surface
 BODY FINISH: metal – black matte powder coating
 BASE FINISH: high performance concrete – natural
 CABLE COLOUR: black charging cable
 USB 2/USB–C, 5V
 LED SOURCE: 12V, LED, 4W, 2700K, RA80+, DIM
PC1271 (CGC39, CGSU66, CCS68, CSFB2840, CECL2837, LEDS2845)
 GLASS COLOUR: triplex opal
 GLASS SURFACE: glossy surface
 BODY FINISH: brushed stainless steel
 BASE FINISH: high performance concrete – natural
 CABLE COLOUR: black charging cable
 USB 2/USB–C, 5V
 LED SOURCE: 12V, LED, 4W, 2700K, RA80+, DIM

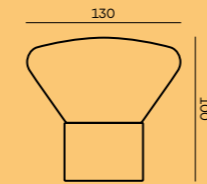

PC1008

p. 280—281 | PH5811
PC1008 (CGC38, CCS592)
 GLASS COLOUR: opaline – transparent glass
 BODY FINISH: European oak – stained black
PC1008 (CGC554, CCS592)
 GLASS COLOUR: violet – transparent glass
 BODY FINISH: European oak – stained black
PC1008 (CGC23, CCS972)
 GLASS COLOUR: transparent glass
 BODY FINISH: European oak – clear coat
PC1008 (CGC540, CCS972)
 GLASS COLOUR: cognac – transparent glass
 BODY FINISH: European oak – clear coat
PC1008 (CGC538, CCS972)
 GLASS COLOUR: smoke brown – transparent glass
 BODY FINISH: European oak – clear coat

p. 282 | PH5973
PC1008 (CGC515, CCS972)
 GLASS COLOUR: amber – transparent glass
 BODY FINISH: European oak – clear coat
PC1008 (CGC157, CCS592)
 GLASS COLOUR: orange – transparent glass
 BODY FINISH: European oak – stained black
PC1008 (CGC554, CCS972)
 GLASS COLOUR: violet – transparent glass
 BODY FINISH: European oak – clear coat
PC1008 (CGC38, CCS972)
 GLASS COLOUR: opaline – transparent glass
 BODY FINISH: European oak – clear coat
PC1008 (CGC540, CCS757)
 GLASS COLOUR: cognac – transparent glass
 BODY FINISH: American walnut – natural waxed
PC1008 (CGC516, CCS757)
 GLASS COLOUR: smoke grey – transparent glass
 BODY FINISH: American walnut – natural waxed

p. 283 | PH5808
PC1008 (CGC540, CCS972)
 GLASS COLOUR: cognac – transparent glass
 BODY FINISH: European oak – clear coat

p. 284—285 | PH977
2*PC1008 (CGC516, CCS757)
 GLASS COLOUR: smoke grey – transparent glass
 BODY FINISH: American walnut – natural waxed
PC1008 (CGC516, CCS972)
 GLASS COLOUR: smoke grey – transparent glass
 BODY FINISH: European oak – clear coat

The lights are listed in the index in the same order as they appear from left in the photograph. For groups of more than five lights, only the codes of the lights are given without further specification of their number within the given photograph.

IMPORTANT INFORMATION

BROKIS products and services can be found on the latest version of our website – www.brokis.cz. Our sales partners are regularly informed of news and any changes to products and/or services. In order to streamline cooperation with our sales partners and promote sales of our products and services, we've created new marketing tools, which are available through the MY BROKIS partner platform at www.mybrokis.cz. These tools, which include ordering, informative documents, PR materials, and an overview of complementary services, support product sales growth and help us develop. BROKIS is also introducing optional product registration, which will allow customers to verify the authenticity of their lights. More information on product registration can be found in a special QR code at the end of the catalogue.

CLEANING INFORMATION

As with all products, BROKIS lights require periodic cleaning. Dust, grease, and film affect the visual quality of any item made of glass.

It is in the interest of the user to maintain the singular appearance of the lights. This can only be achieved through regular cleaning. When neglected, the cleaning process becomes unnecessarily time consuming. The cleaning interval depends on the environment the lights are installed in and is primarily influenced by humidity levels, temperature stability, and the amount of dust in the air.

BROKIS applies the highest possible quality standards in manufacturing its lights. Prior to shipping, each light undergoes several quality controls and stages of cleaning. Lights may require additional cleaning as a result of transportation, storage, and the amount of time that passes between packing and subsequent unpacking by the client. Therefore, we recommend cleaning the lights prior to installation.

RECOMMENDED CLEANING METHODS

When cleaning lights from any of our collections, we recommend first disassembling them according to the instructions in the installation manual and then securing the glass components against mechanical damage.

The glass must first be rinsed in hot water and a dilution of dish detergent to remove all foreign particles and dust. Repeat this process if necessary. The glass must then be cleaned a second time using hot water and a dilution of degreaser (such as ammonia or vinegar) and thoroughly rinsed under running hot water. Repeat this process if necessary. Next, dry the glass thoroughly with a paper or a soft cotton towel. Only reassemble the light once the glass has cooled completely.

Do not use mineral spirits, highly concentrated thinners, or other substances not intended for use on glass surfaces. Do not use products containing silicone, since they quickly attract more dust and grease.

BROKIS
WEBSITE



BROKIS
PROJECTS



MY
BROKIS



PROMO
VIDEO



BROKIS VIRTUAL
PROJECTS



BROKISGLASS



BROKIS
CATALOGUE



TECHNICAL INFORMATION
ABOUT PRODUCTS



Cleaning information
and unpacking the box



Technical
information



Product
registration



ARCHI
TONIC



archiproducts



archilovers



BROKIS, s.r.o.

OFFICE

Španielova 1315/25
163 00 Prague 6
Czech Republic

SHOWROOM

Sídlíště Janštejn 39
588 52 Horní Dubenky
Czech Republic

www.brokis.cz
info@brokis.cz

DESIGNERS

Lucie Koldova
Dan Yeffet
Boris Klimek
Chiaramonte Marin
Fumie Shibata
Lenka Damová
Vrtiška & Žák
LCM MARIN design studio

PHOTO

Martin Chum
Adéla Havelková
Kristina Hrabětová
Lukáš Pelech
Jan Voharčík
Denise Keus
Zbyněk Krulich
Polygoniq
Studio Salaris
SUPREMA
Artur de Menezes

GRAPHIC DESIGN

Studio Marvil

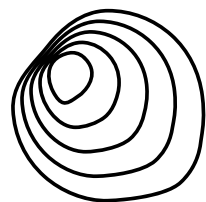

BROKIS®

CM14753

